

Underfloor Heating

Installation Guide

Contents

Technical Data **Page - 2**

Preparing the Sub-Floor **Page - 2**

Testing **Page - 2**

Installation **Page - 3/4**

Warranty Information **Page - 4**

Recycling & Disposal **Page - 4**

Contact us **Page - 4**

Technical data

Underfloor heating mats are constructed using insulated, twin core heating cable, which includes high performance insulation, around the heater wires and either a braided or wrapped metal earth screen, with a further outer layer of polymer insulation. This is then fixed into a special fibre mesh, with the cable spaced at 75mm. To give a regulated heating output of 150w/sqm for TMP. The cable complies with industry guidelines for safe use on timber as well as solid sub-floors. All mats have been rigorously tested and surpass all European standards requirements. The mats are normally installed under ceramic, quarry or natural stone tiles. For use under other surfaces, such as hardwood and laminate flooring, simply screed over the cable and lay the alternative flooring as normal.

The heating cable of each mat is terminated at one end with a 4 metre long cold power supply cable, for connection to the combined timer/ thermostat control unit. Each heating cable has a fixed resistive length and cannot, therefore, be shortened. There are 14 sizes of mat available, which can be used singly or in a combination to accommodate any floor area by connecting in parallel.

We strongly recommend that all electrical work is carried out by a qualified electrician and must conform to current IEE wiring regulations. The heating mats should be installed in conjunction with a floor temperature sensing Timerstat control and be connected via a RCD (residual current device) protected circuit.

1.0 (150w/0.7amp) - 0.5m x 2m = 1sq/m 353Ω
1.5 (225w/1.0amp) - 0.5m x 3m = 1.5sq/m 235Ω
2.0 (300w/1.3amp) - 0.5m x 4m = 2sq/m 176Ω
2.5 (375w/1.6amp) - 0.5m x 5m = 2.5sq/m 141Ω
3.0 (450w/2.0amp) - 0.5m x 6m = 3sq/m 118Ω
4.0 (600w/2.6amp) - 0.5m x 8m = 4sq/m 88Ω
5.0 (750w/3.3amp) - 0.5m x 10m = 5sq/m 71Ω
6.0 (900w/3.9amp) - 0.5m x 12m = 6sq/m 59Ω
7.0 (1050w/4.6amp) - 0.5m x 14m = 7sq/m 50Ω
8.0 (1200w/5.2amp) - 0.5m x 16m = 8sq/m 44Ω
9.0 (1350w/5.9amp) - 0.5m x 18m = 9sq/m 39Ω
10 (1500w/6.5amp) - 0.5m x 20m = 10sq/m | 35Ω

Preparing the Sub-Floor

The most important consideration when installing a tiled floor, whether it is to be heated or not, is the preparation of the sub-floor prior to tiling. It is essential that it is sound and level and will support the weight without movement or deflection. The following recommendations are a general guide only and you should seek further advice from the Tiler and the tile and adhesive manufacturer.

Timber Floors

The existing floorboards must first be securely fixed and level. This should then be over boarded with either a suitable insulated tile backer board or 18mm W.B.P. plywood. The back and edges of the plywood should be sealed before laying and then, with plated screws, fixed to the floor joists at 200mm centres, plus additional fixings at the board edges. If using a tile backer board, this should be installed following the manufacturer's instructions.

Solid Floors

Concrete floors should be completely dry, which, with newly laid concrete, can take many weeks to fully cure and dry. Remove all traces of old floor coverings and adhesive and ensure that the surface is smooth and level. Although the heating mats can be laid directly onto a sound, dry concrete floor, we recommend the use of insulated tile backer board for improved performance and efficiency of the heating system.

Preparing the Electrical Supply

We recommend that this work be carried out prior to preparing the sub-floor and laying the heating mat. This work should be carried out by a qualified electrician and comply with IEE regulations.

If more than 2 mats are to be installed, a junction box will be required to connect up the heaters in parallel for ease of connection to the thermostat. Please refer to the thermostat installation guide for more information.

Testing the Continuity and Resistance

Prior to installing the heating mat always check the continuity and resistance with an Ohmmeter, to ensure that there is a circuit and that the cable is not damaged. The readings should be approximately similar to that on the ratings label on the mat, or as shown in the table on the previous page under electrical installation. The test should also be repeated periodically during installation and prior to, during and on completion of tiling or installing the finished floor.

Installation

Please read carefully...

- ✗ **DO NOT** attempt to modify this product in any way.
- ✓ Any electrical work must be carried out by a qualified electrician.
- ✓ Wear appropriate safety shoes while installing.
- ✓ If you are unsure how to install this product, please consult a qualified installer or contact us directly.
- ✗ Cables within the heating mat cannot be cut or shortened in any way.
- ✓ Please ask your Electrician to test the mat , before, during and after installation to prevent any issues once installed.

Parts Included:

Underfloor heating mat

Tools required for installing:

Scissors

Foam Paint roller (optional)

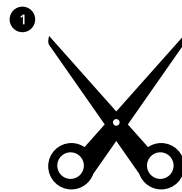

It is a good idea to lay out the installation without securing the mat, to ensure that you have the correct size. Take care not to cut or damage the cable with sharp tools and wear soft soled shoes throughout. Never cross the heating element wire or cross the cold leads or temperature sensor wire underneath or over the top of the mat. The heating cable should not be closer than 50mm to avoid hot spots.

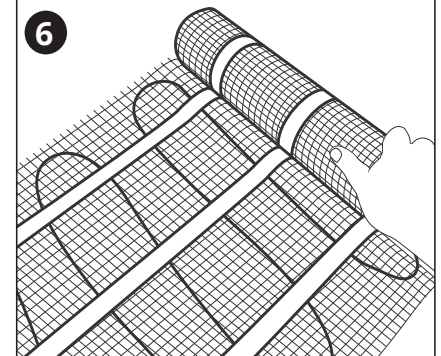
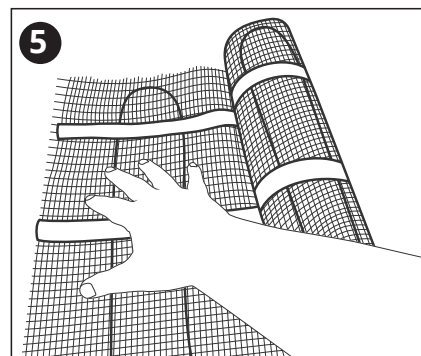
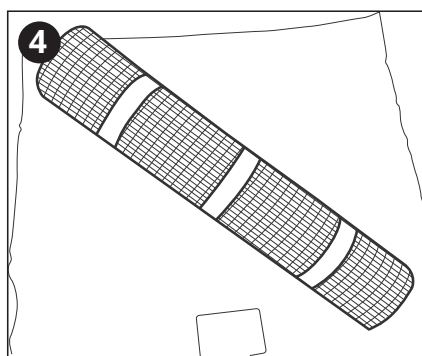
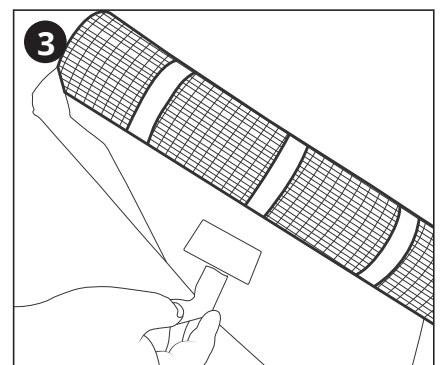
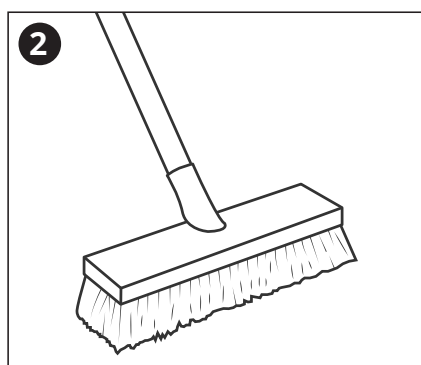
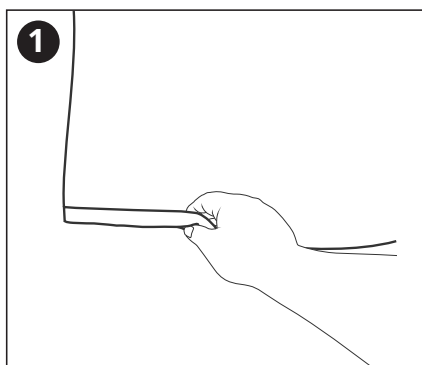

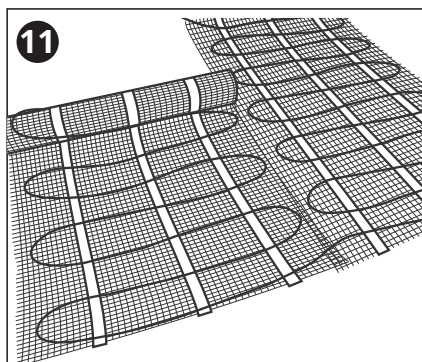
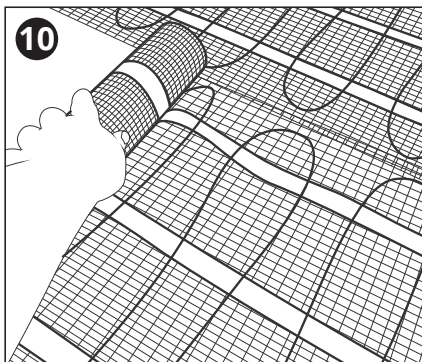
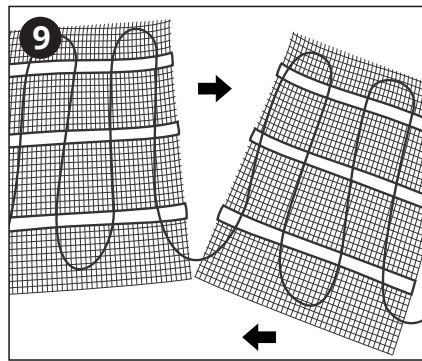
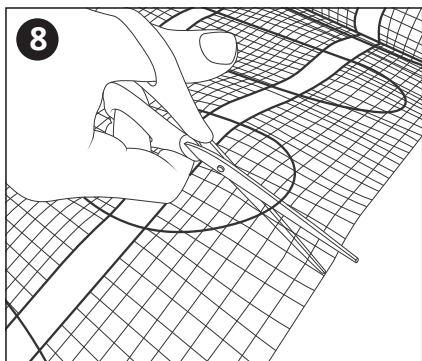
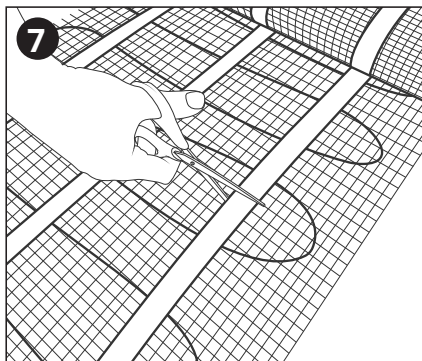

Continue to roll the mat out until the required area is covered, repeating the above steps as required.

Please remember to not cut any of the wires!

To connect the mat to the thermostat, please see the thermostat installation guide, we recommend this is done by a qualified electrician.

Warranty Information

- *To find the specific guarantee for your product please refer to the website.*
- *The guarantee starts from the date of purchase.*
- *The guarantee covers you against issues caused as a result of manufacturing related issues, it does not apply to issues that are found to be a result of poor installation.*
- *Labour costs for installation of the product are not covered under this warranty.*

Recycling & Disposal

The Waste Electrical and Electronic Equipment Directive (WEEE Directive) is the European Community directive 2012/19/EU on Waste Electrical and Electronic Equipment (WEEE) which, together with the RoHS Directive 2002/95/EC, became European Law in February 2003

The WEEE directive aims to reduce the amount of electrical equipment being produced and to encourage everyone to reuse, recycle and recover it.

In support of these guidelines and for environmental safety, do not dispose of any electrical equipment including those marked with the below symbols

When replacing old electrical devices with new ones the retailer is legally obligated to take back your old items for disposal free of charge. You can also recycle your old electrical devices free of charge at your local recycling centre. Please contact your local council for more information.

Contact Us

Milano
Unit 1&2
Dawson Court
Burnley
BB11 5UB

