

# biard

## Stainless Steel E27 Post Lamp

### Installation Guide

#### **Contents**

Safety Information **Page - 2**

Installation **Page - 3**

Warranty Information **Page - 5**

Recycling & Disposal **Page - 5**

# Safety Information

---

## *Please read carefully...*

- ✓ Switch off the power while installing
- ✗ Do not use this product with a dimmer switch
- ✓ We recommend installation is performed by a qualified electrician
- ✓ Avoid looking directly into the light when switched on.
- ✗ Do not modify this product, this will invalidate your warranty
- ✗ Read all the instructions in the manual before beginning installation if in doubt use a qualified electrician.
- ✓ IP54 - For indoor and outdoor use.
- ✓ Inspect the product for damage before installation

---

## Other Information

**Do not wire this lantern into the lighting circuit - use a switched fuse spur.**

**This fitting must be earthed. contact a qualified electrician to install a suitable earth facility.**

**For new installations, check for any electrical cables or pipe work (gas/water) in the vicinity of the intended mounting point for this product, before proceeding with the installation.**

### ***RISK OF FIRE***

Clearance required from Floor- Min 150cm

Clearance from any flammable material - Minimum 150mm

### ***Parts required-***

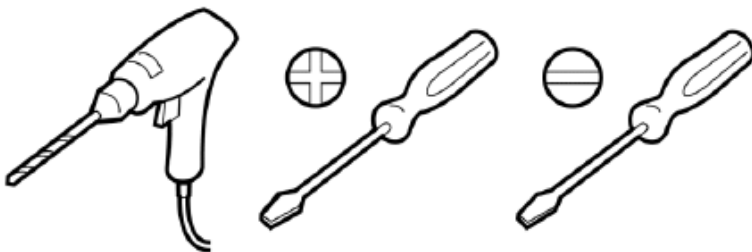

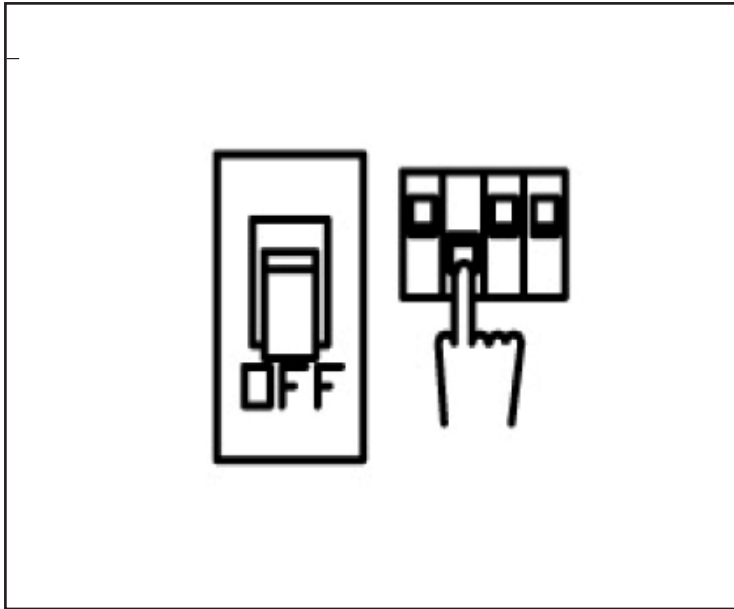

Turn off the power at the mains.

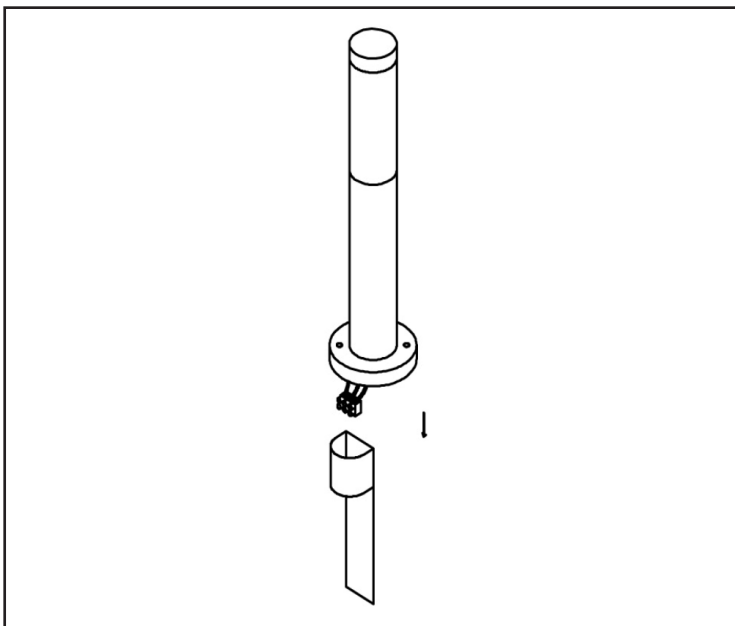

Remove the ground spike from the main body of the post lamp

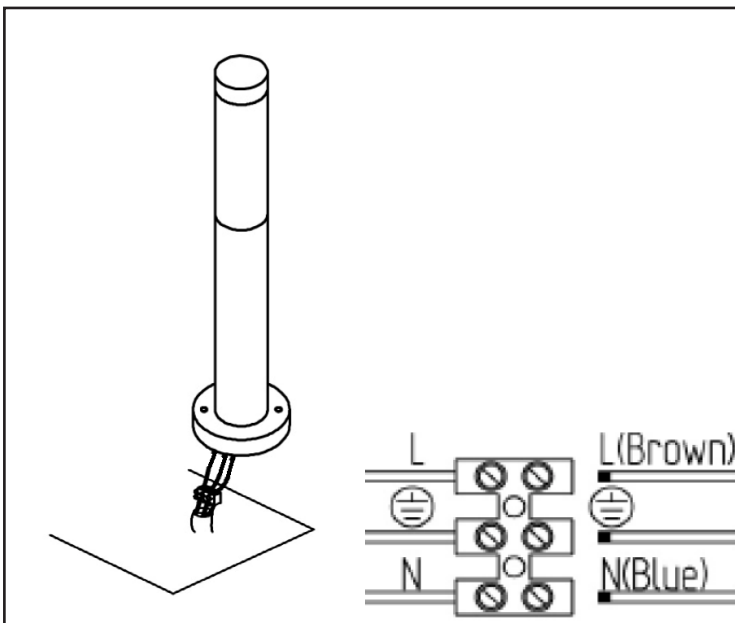

Feed the mains cable up through the ground at your chosen fixing location, feed it through the centre of the ground spike and connect as shown.

**Connect the BROWN wire to the terminal block marked "L" (Live wire).**  
**Connect the BLUE wire to the terminal block marked "N" (Neutral wire).**  
**Connect the YELLOW/GREEN wire to the terminal block marked E (Earth wire)**

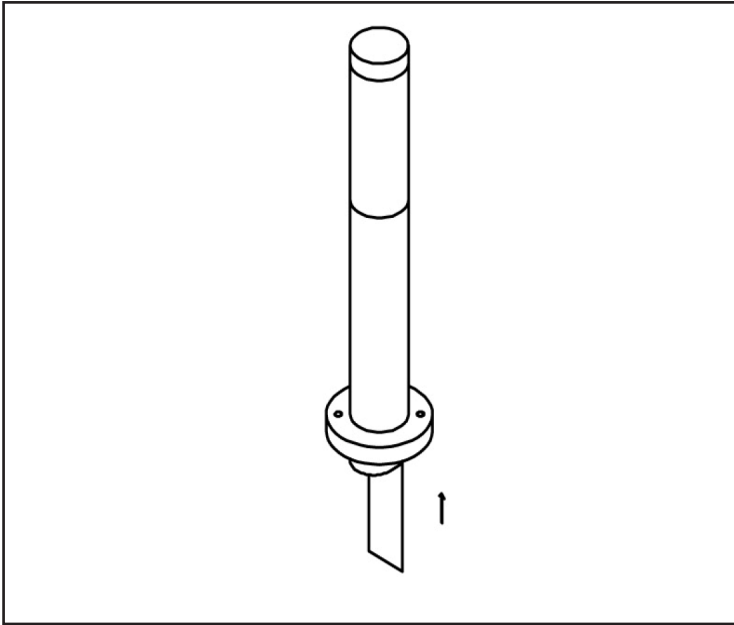

Push the ground spike back into the body of the post.

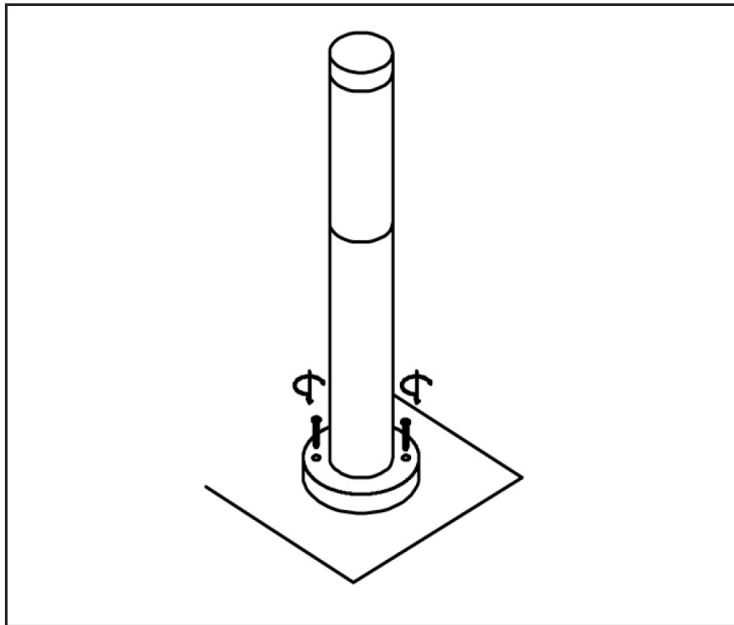

Offer the post to the ground and fix in place with the supplied screws.

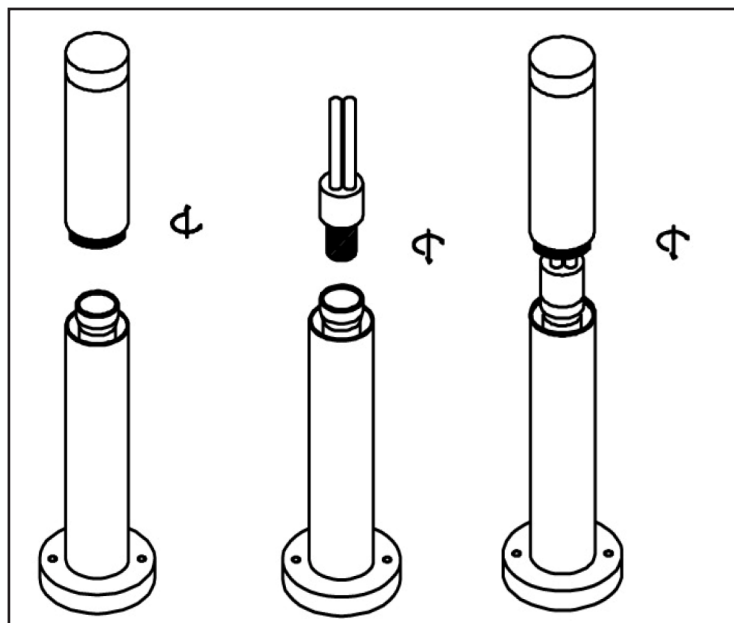

Unscrew the upper section of the post, screw in the lightbulb and re-attach the upper section.

# Warranty Information

---

- *This product is covered by the standard indoor Biard 5 limited year warranty for any manufacturing faults.*
- *The warranty starts from the date of purchase.*
- *The warranty period is based on a burning behaviour of max. 4000 hours/year. In case of more than 4000 hours/year, the warranty period will be adjusted pro-rata.*
- *Labour costs for installation of the Product are not covered under this warranty.*
- *The warranty is only valid when products are properly installed and operated as specified in this manual and the data sheets.*
- *All warranty queries should be through the stockist that the product was purchased through.*

# Recycling & Disposal

---

**The Waste Electrical and Electronic Equipment Directive (WEEE Directive)** is the **European Community directive** 2012/19/EU on **Waste Electrical and Electronic Equipment (WEEE)** which, together with the **RoHS Directive** 2002/95/EC, became European Law in February 2003

The **WEEE** directive aims to reduce the amount of electrical equipment being produced and to encourage everyone to reuse, recycle and recover it.

In support of these guidelines and for environmental safety, do not dispose of any electrical equipment including those marked with the below symbols

When replacing old electrical devices with new ones the retailer is legally obligated to take back your old items for disposal free of charge. You can also recycle your old electrical devices free of charge at your local recycling centre. Please contact your local council for more information.



Consult instructions for use