

# Milano

## Lustro Towel Rail & Heating Element

### Installation Guide

#### **Contents**

Intended use & Safety Information **Page 2**

Element Installation **Page - 3/4**

Radiator Installation **Page - 4/5**

Electrical Connection **Page - 6**

Your Guarantee **Page - 6**

Aftercare **Page - 6**

Recycling & Disposal - **Page 6**

Contact Us **Page - 6**

# Intended Use & safety Information

---

## ***Please read carefully...***

This product is intended for use in domestic or commercial environments such as homes, shops, hotels etc.

This product is not intended for use in a corrosive or explosive atmosphere (dust, vapor or gas)

This appliance can be used by children aged from 8 years and above and persons with reduced physical, sensory or mental capabilities or lack of experience and knowledge if they have been given supervision or instruction concerning use of the appliance in a safe way and understand the hazards involved. Children shall not play with the appliance. Cleaning and user maintenance shall not be made by children without supervision.

Children ages from 3 years and less than 8 years shall only switch on/off the appliance provided it is placed or installed in its intended normal operating position and they have been given supervision or instruction concerning use of the appliance in a safe way and understand the hazards involved.

Children aged from 3 years and less than 8 years shall not plug in, regulate and clean the appliance or perform user maintenance.

Children of less than 3 years should be kept away unless continuously supervised.

**CAUTION:** The surface of this product can become very hot and cause burns, please pay attention when children or vulnerable people are around the heater.

This product should be installed by a qualified installer in accordance with all applicable local regulations and connected to an electrical output in good condition.

Extension leads or plug adapters should not be used in order to supply power to this product.

**WARNING:** In order to avoid overheating, do not cover the heater.

The element cord cannot be replaced. If the cord is damaged the element should be removed and disposed of.

This product can be installed in zone 1, 2 or outside the zones when installing in a bathroom, all local regulations should be adhered to.

**WARNING:** To ensure the safety of very small children, install the product so the lowest tube is at least 300 mm above the floor.

## General Information

Do not throw away packaging until you have located and confirmed that you have all included parts and the product is in good condition.

Check the device for damage before installation and on a regular basis. If any damaged is found on the radiator or element it should not be used, if any damage is caused once installed or during installation the device should be switched off and disconnected immediately.

Keep the element power cord away from any hot surfaces of the radiator. This radiator or element has no serviceable parts, never dismantle the radiator as this will invalidate the warranty and could lead to injury.

Please read the full manual before installing. 

# Installation

---

## Tools required for installing:

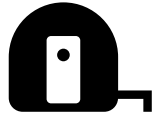

## Installation Safety Information

---

Always disconnect the power before installing.

If in any doubt contact a qualified or fully competent person.

The product should only be connected to a power outlet in good condition.

Local electrical regulations must be adhered to when installing.

Please pay attention to the safety zones if installing in a bathroom.

This product must not be located immediately below a socket outlet.

## Installing The Heating Element

---

### Tools required for installing:

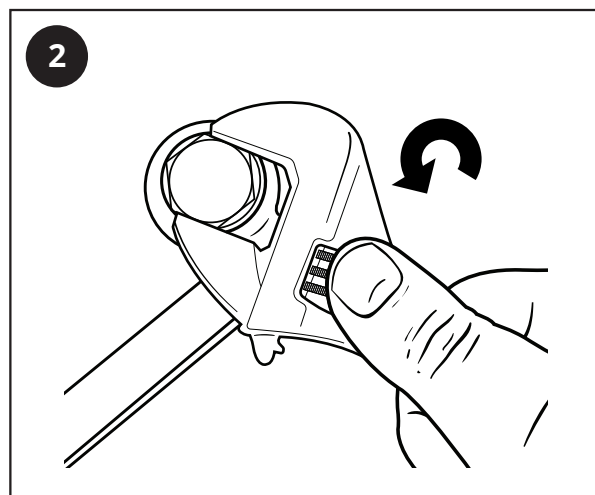
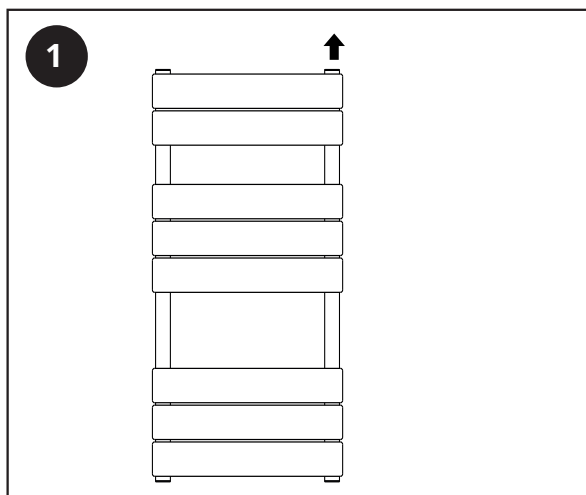

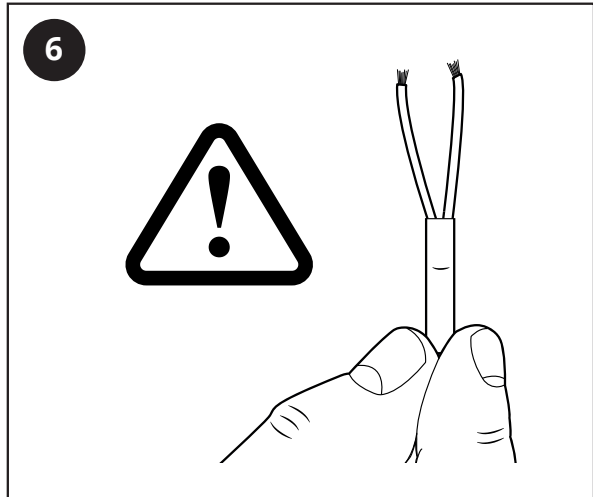
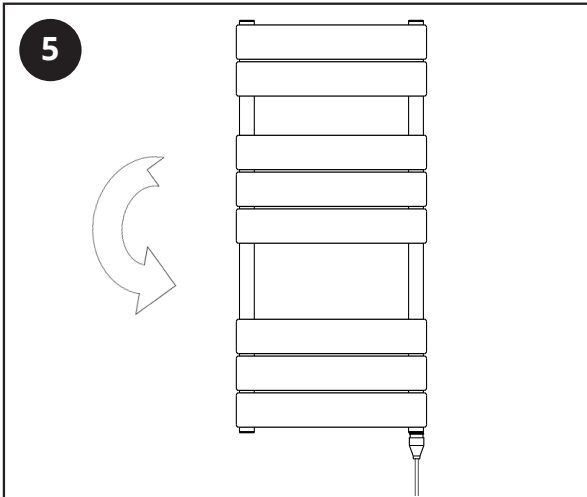
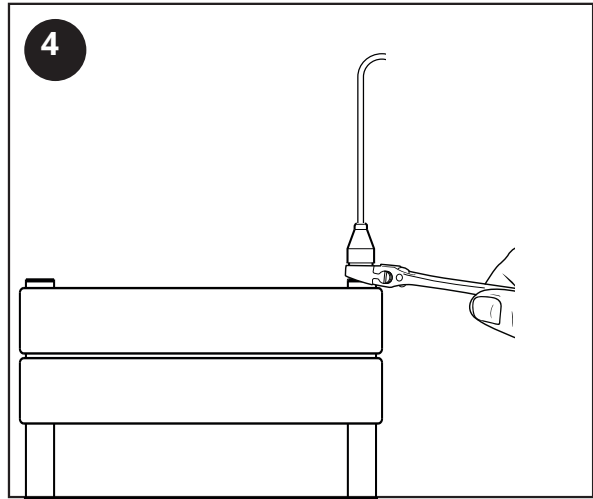
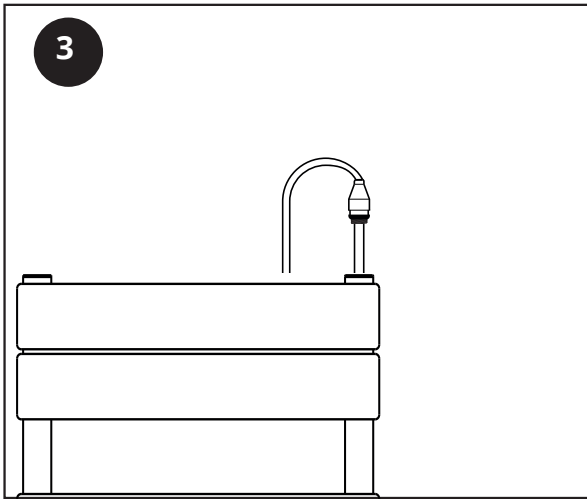

The towel rail can now be turned over so the heating element is facing downwards ready for installing on the wall.

## Installing The Towel Rail

### Parts Included:

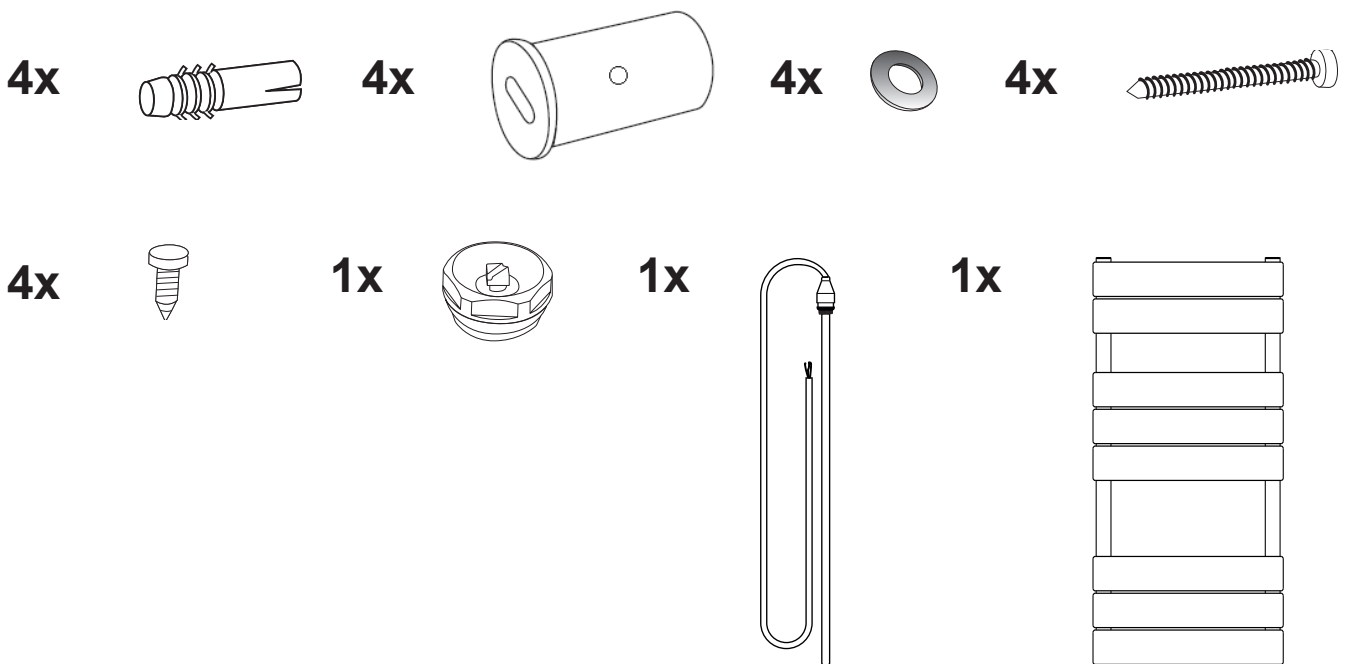

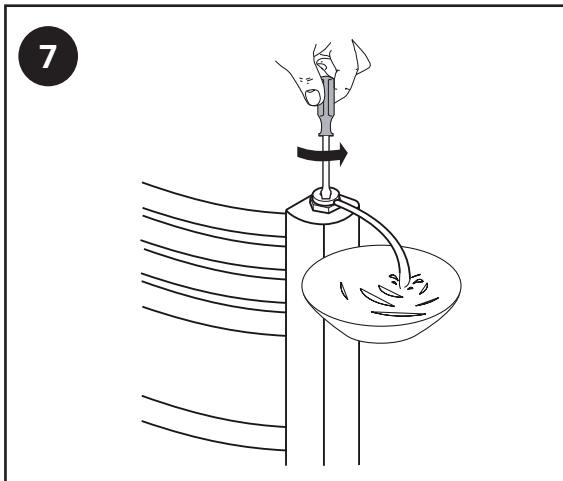
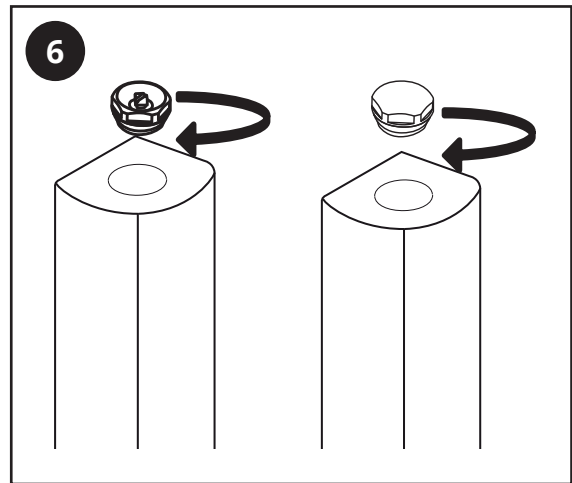
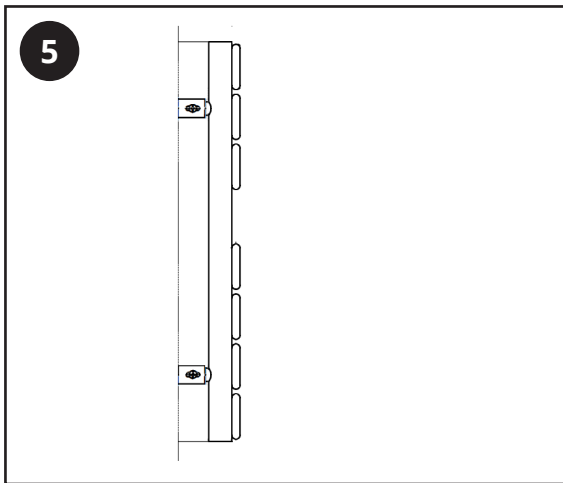
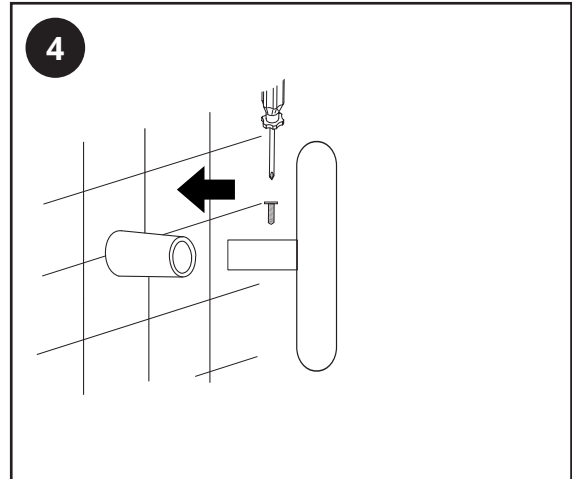
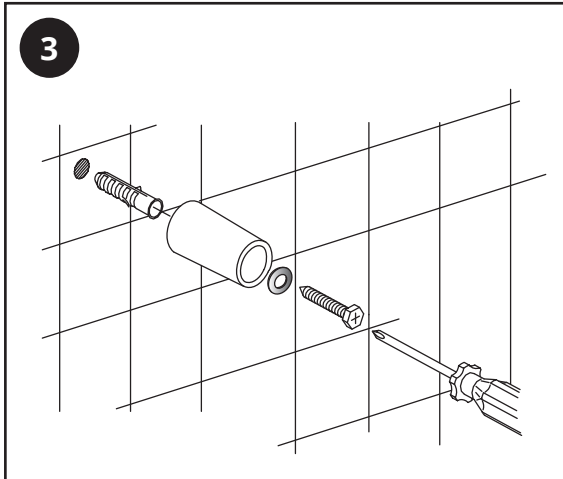
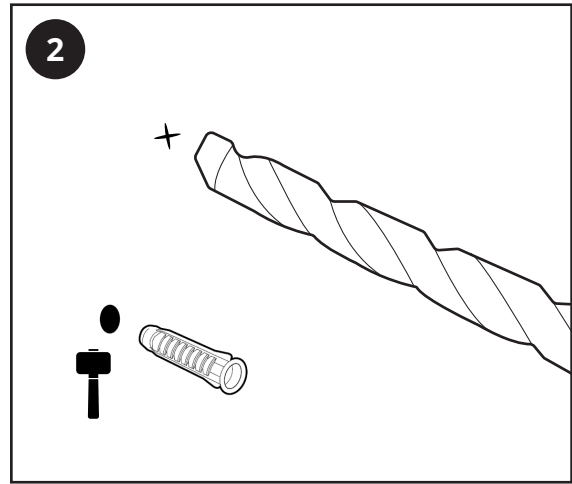
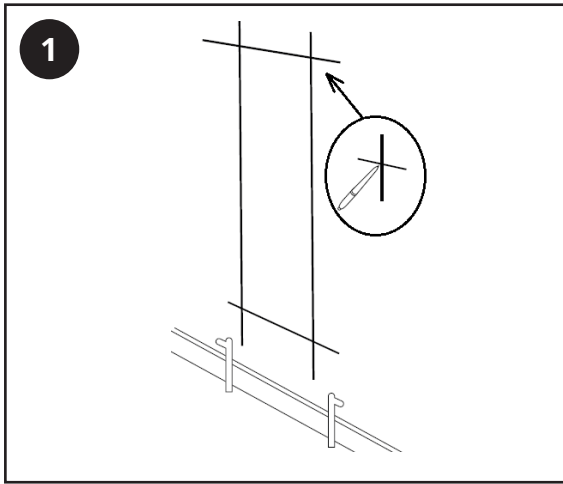

# Electrical Installation

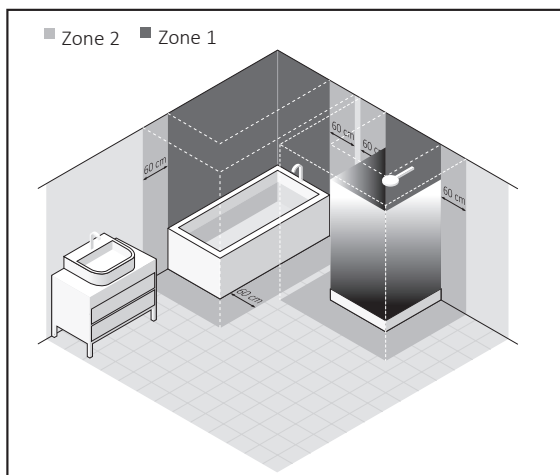
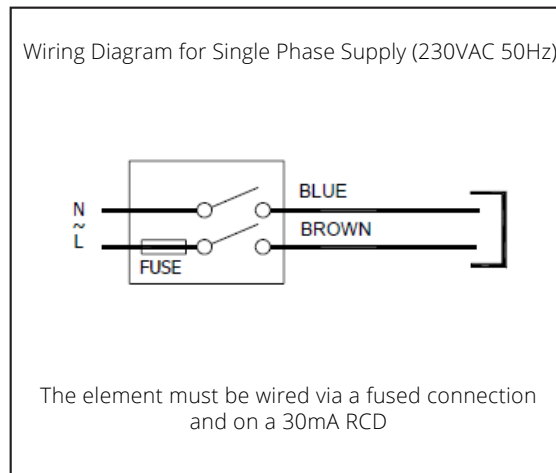
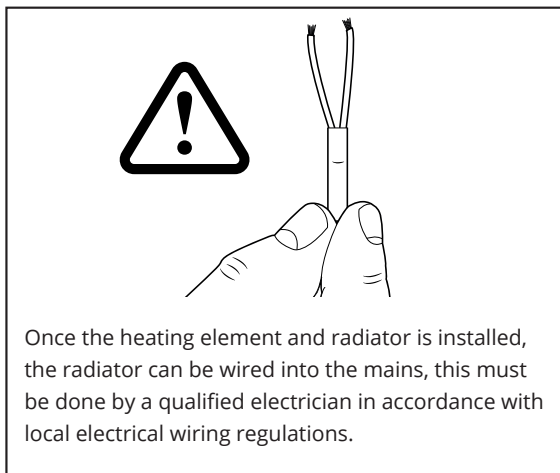

The heating element can be installed in bathrooms in zone 1, 2 and outside the zones as defined by applicable law, subject to any additional regulations concerning electrical installations in wet areas.

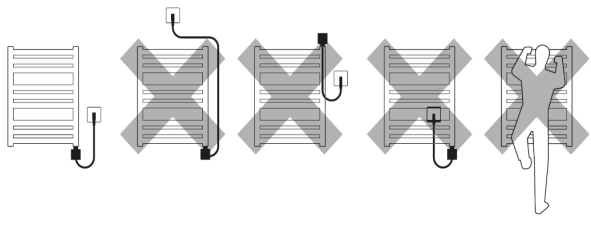

## Your Guarantee

To find the specific guarantee for your products please refer to the website.

The guarantee starts from the date of purchase.

The guarantee covers you against issues caused as a result of manufacturing related issues, it does not apply to issues that are found to be a result of poor installation.

Labour costs for for installation of the products are not covered under this warranty.

## Aftercare

Clean any marks with a soft, dry or damp cloth, for stubborn stains please clean with mild soapy water and dry with a soft cloth. DO NOT use abrasive or acidic cleaners.

If you are unsure, please contact us first.

## Recycling and Disposal

The **Waste Electrical and Electronic Equipment Directive (WEEE Directive)** is the **European Community directive 2012/19/EU on Waste Electrical and Electronic Equipment (WEEE)** which, together with the **RoHS Directive 2002/95/EC**, became European Law in February 2003

The WEEE directive aims to reduce the amount of electrical equipment being produced and to encourage everyone to reuse, recycle and recover it.

In support of these guidelines and for environmental safety, do not dispose of any electrical equipment including those marked with the below symbols

When replacing old electrical devices with new ones the retailer is legally obligated to take back your old items for disposal free of charge. You can also recycle your old electrical devices free of charge at your local recycling centre.

Please contact your local council for more information.

Please recycle the packaging in accordance with your local government regulations on waste handling and follow the same advice at the end of the products life.

Product - Steel.

Packaging - Cardboard, plastic, steel.

## Contact us

Unit 1 & 2 Dawson Ct

Burnley

Lancashire

BB11 5UB