

Bestway®

LAY-Z-SPA®



bestwaycorp.com/support



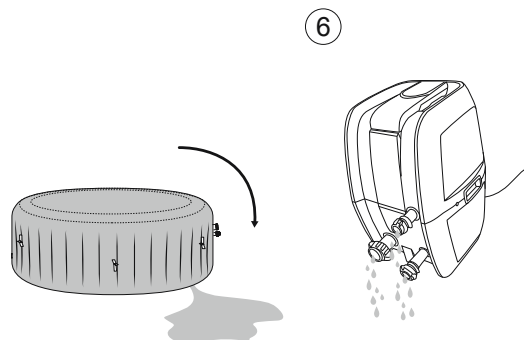
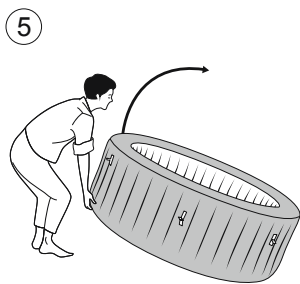
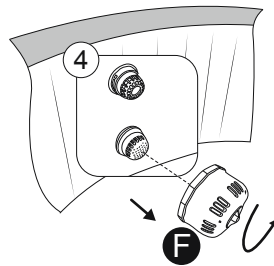
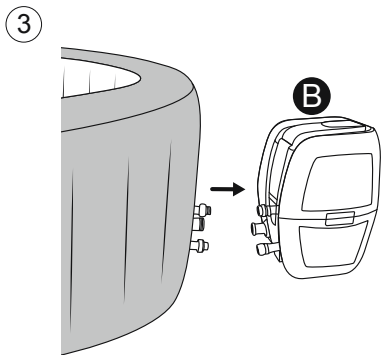
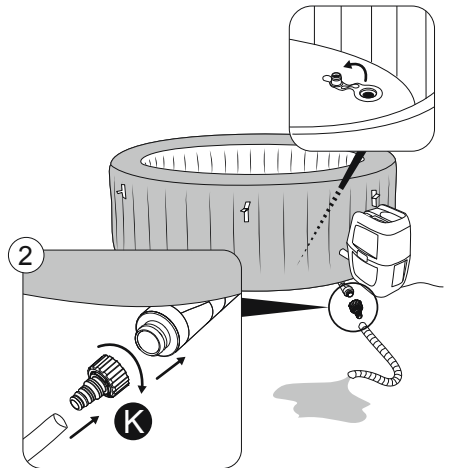
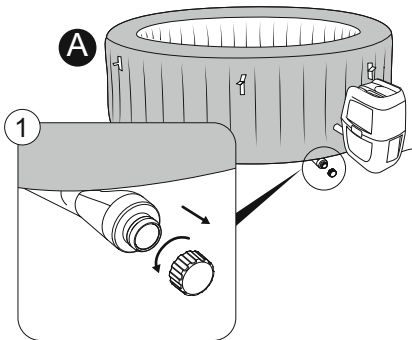



A: ①



②

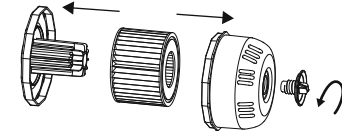

③

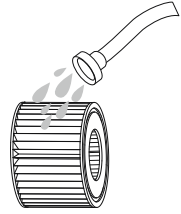

B: ①

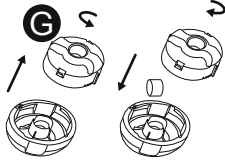

②

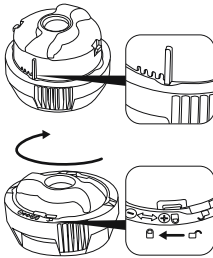

③

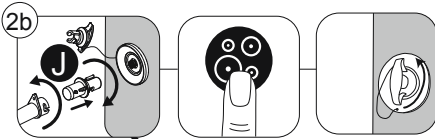
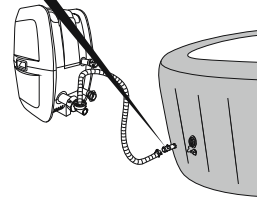
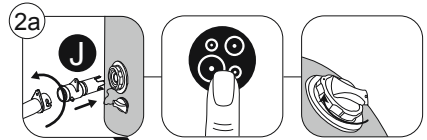
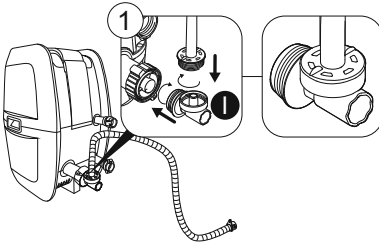
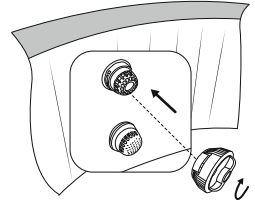

③

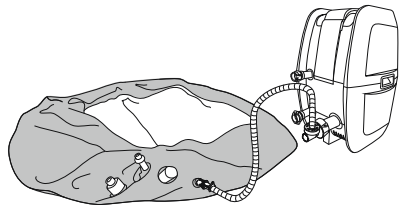
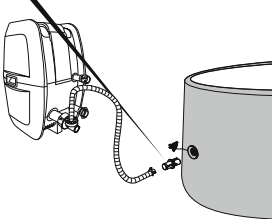



LAY-Z-SPA®

OWNER'S MANUAL

TABLE OF CONTENTS

SAFETY INFORMATION PAGE 6

- Carefully read over the important safety instructions and warnings before operating and keep this manual for future reference. Failure to follow safety information can result in serious injury or death to users.

PRODUCT DESCRIPTION PAGE 11

- Carefully read all product information provided in this manual, including the specifications of the heater. The hot tub heater must be used with an outlet with the corresponding voltage and rating.

PARTS & TOOLS NEEDED PAGE 11

- To check the parts included in the box, consult the part list on the package. Verify that the equipment components represent the model that you had intended to purchase.
- In case of any damaged or missing parts at the time of purchase, visit our website bestwaycorp.com/support.

SETUP INSTRUCTIONS PAGE 11

- For the installation instructions, refer to the illustration steps on the package. Drawings are for illustration purposes only. May not reflect actual product. Not to scale.
- Bestway will not be responsible for any damage caused to the hot tub due to mishandling or failure to follow these instructions.

USAGE INSTRUCTIONS PAGE 13

- For the usage instructions, refer to the illustration steps in this manual. Drawings are for illustration purposes only. May not reflect actual product. Not to scale.
- Bestway will not be responsible for any damage caused to the hot tub due to mishandling or failure to follow these instructions.

MAINTENANCE INSTRUCTIONS PAGE 15

- Liner, cover, filter cartridge, water and chemical maintenance must be performed for the health of your hot tub. Not adhering to guidelines in this section might put you and your family's health at risk.

TABLE OF CONTENTS

DISASSEMBLY & STORAGE INSTRUCTIONS PAGE 16

- Be sure that your hot tub is completely clean and dry before storage. If all parts are not completely dry, mold may result.
- Store in a dry place with a moderate temperature between 15°C (59°F) and 38°C (100°F).

TROUBLESHOOTING PAGE 18

- For help with issues with your hot tub, please consult the Troubleshooting section of this manual.

ERROR CODES PAGE 20

- For help with issues with your hot tub, please consult the Error Codes section of this manual.

WARRANTY INFORMATION PAGE 22

- For information concerning warranty terms, visit our website at www.bestwaycorp.com.

SAFETY INFORMATION

READ AND FOLLOW ALL INSTRUCTIONS.

Carefully read, understand, and follow all information in this user manual before installing and using the spa. These warnings, instructions, and safety guidelines address some common risks of water recreation, but they cannot cover all risks and dangers in all cases. Always use caution, common sense, and good judgment when enjoying any water activity. Retain this information for future use. In addition, the following information can be supplied depending on the spa type. Keep these instructions in a safe place. If instructions are missing, please contact the manufacturer or search it on the website www.bestwaycorp.com.

WARNINGS – SAFETY INSTALLATION

- The spa must be supplied through an isolating transformer or supplied through a residual current device (RCD) having a rated residual operating current not exceeding 30mA.
- The spa must be supplied by an earthed power source.
- The power source on the wall of building should be more than 4 m (13.1 feet) away from the pool.
- The spa must be connected to a grounded mains supply socket with a supply cord fitted with a plug and PRCD with a tripping current of 10mA.
- The SPA must only be plugged directly into an earthed socket-outlet of the fixed wiring.
- It is necessary to have the plug accessible after installation of the spa.
- Electric installations should follow national wiring rules, consult a qualified electrician with any questions.
- Do not bury cord. Locate cord to minimize abuse from lawnmowers, hedge trimmers, and other equipment.
CAUTION: In order to avoid a hazard due to inadvertent resetting of the thermal cut-out, this appliance must not be supplied through an external switching device, such as a timer, or connected to a circuit that is regularly switched on and off by the utility.
- Read the instructions before using the appliance and installation or reassembly every time.

WARNINGS - RISK OF ELECTRIC SHOCK TO AVOID ELECTRIC SHOCK, DO NOT USE THE SPA WHEN IT IS RAINING, THUNDERING OR LIGHTNING.

- Don't use extension cord to connect unit to electric supply; provide a properly located outlet.
- Don't plug or unplug the appliance if your hand is wet.

SAFETY INFORMATION

- Never operate any electrical appliance when in your spa or when your body is wet. Never place any electric appliance, such as a light, telephone, radio, or television, within 2 m (6.6 feet) of the spa.
- Install at least 2 m (6.6 feet) from all metal surfaces.
- No part of the appliance is to be located above the bath during use.
- Parts containing live parts, except parts supplied with safety extra-low voltage not exceeding 12V, must be inaccessible to a person in spa pool; Parts incorporating electrical components, except remote control devices, must be located or fixed so that they cannot fall into the spa pool.
- For electric safety, a PRCD is incorporated in the power cord. If the current leakage is detected more than 10mA, the device will operate and cut-off the power supply. In such case, please unplug and stop using the spa at once. Don't repair the product by yourself. Visit our website www.bestwaycorp.com to get the necessary information.
- If the supply cord is damaged, it must be replaced by the manufacturer, its service agent or similarly qualified persons in order to avoid a hazard.
- To reduce the risk of electric shock, do not use extension cord to connect unit to electric supply; provide a properly located outlet.

WARNING - RISK OF FIRE AND OVERHEATING

- Do NOT use extension cord or multi-plug adapter with spa heater. Plug directly into grounded socket.

WARNINGS- TO REDUCE THE RISK OF INJURY

- The water in a spa should never exceed 40°C (104°F). Water temperature between 38°C (100°F) and 40°C (104°F) is considered safe and comfortable for a healthy adult. Lower water temperatures are recommended for young children and when spa use exceeds 10 minutes.
- Since excessive water temperatures have a high potential for causing fetal damage during the early months of pregnancy, pregnant or possibly pregnant women should limit spa water temperature to 38°C (100°F). Limit use to 10 minutes at a time.
- If you feel the water is too hot, before entering a spa, the user should measure the water temperature with an accurate thermometer. If the water temperature is above 45°C (113°F), stop use of the spa until the temperature is reduced to under 40°C (104°F). When using an external thermometer, the temperature showed on the control panel and the external thermometer may be different. The difference should be around 3 degrees. This situation is normal due to the different location where the two instruments read the temperature.
- The use of alcohol, drugs, or medication before or during spa use may lead to unconsciousness with the possibility of drowning.
- Obese people and people with a history of heart disease, low or high blood pressure, circulatory system problems, or diabetes should consult a physician before using a spa.
- People using medication should consult a physician before using a spa since some medication may induce drowsiness while other medication may affect heart rate, blood pressure, and circulation.
- Avoid putting your head under the water at all times.
- Avoid swallowing spa water.
- Consider that the comfortable temperature range during use may be lower than the maximum safe temperature.
- Never operate the spa if inlet/outlet pipes are broken or missing. Never attempt to replace the inlet/outlet pipes. Visit our website www.bestwaycorp.com to get the necessary information.
- Never pour water with a temperature higher than 40°C (104°F) into the spa pool directly.
- Do not use the spa alone.
- People with infectious diseases should not use a spa.
- Do not use the spa immediately following strenuous exercise.
- Immediately leave the spa if you feel uncomfortable or sleepy.
- Always enter and exit the spa slowly and cautiously. Wet surfaces are slippery.
- The pump must be tested before each use. To test, follow the instructions of pump.
- Always keep plug dry, plug in with wet plug is definitely forbidden.

SAFETY INFORMATION

- Always unplug the appliance:
 - Before cleaning or other maintenance.
 - If leaving it unattended on holidays.
- Never wear your contact lenses when in your spa.

DANGER - Risk of Injury. The suction fittings in this spa are sized to match the specific water flow created by the pump. Should the need arise to replace the suction fittings or the pump, be sure that the flow rates are compatible. Never operate the spa if the suction fittings are broken or missing. Never replace a suction fitting with one rated less than the flow rate marked on the original suction fitting.

CAUTION: After using your spa for 3-5 years, to ensure the safety and performance of the spa, the main components, such as the heating element, air blower motor and non-return valves have to be checked by a professional electrician. If the electrician finds problems during the inspection, visit our website www.bestwaycorp.com to get the necessary information.

WARNINGS – NON-SWIMMERS SAFETY

- Continuous, active, and vigilant supervision of weak swimmers and non-swimmers especially in exercise spas, by a competent adult is required at all times (remembering that children under five years of age are at the highest risk of drowning).
- Designate a competent adult to supervise the spa each time it is being used.
- Weak swimmers or non-swimmers should wear personal protection equipment, especially when using the exercise spa.
- When the spa is not in use, or unsupervised, remove all toys from the spa and its surrounding area to avoid attracting children to the spa.

WARNINGS – SAFETY DEVICES AND EQUIPMENT

- A safety cover or other safety protection device shall be used, or all doors and windows (where applicable) shall be secured to prevent unauthorized access to the spa.
- Barriers, covers, alarms, or similar safety devices are helpful aids, but they are not substitutes for continuous and competent adult supervision.
- It is recommended to keep rescue equipment (e.g. a ring buoy) by the spa (if appropriate).
- Keep a working phone and a list of emergency phone numbers near the spa.
- It is recommended to consult experts and/or local authorities to apply local or national laws/regulations relating to childproof fencing, safety barriers, lighting, and other safety requirements.

WARNINGS – SAFE USE OF THE SPA

- Encourage all users especially children to learn how to swim.
- Learn Basic Life Support (Cardiopulmonary Resuscitation - CPR) and refresh this knowledge regularly. This can make a life-saving difference in the event of an emergency.
- Instruct all spa users, including children, what to do in case of an emergency.
- Never dive into any shallow body of water. This can lead to serious injury or death.
- Do not use the spa when using alcohol or medication that may impair the bather's ability to safely use the spa.
- When covers are used, remove them completely from the water surface before entering the spa.
- Protect spa occupants from water related illnesses by advising them to keep water treated and practicing good hygiene. Consult the water treatment guidelines in the user's manual.
- Store chemicals out of the reach of children.
- Use the signage provided on the spa or within 2 meters of the spa in a prominent visible position.
- Removable ladders, when removed, shall be stored safely where children cannot climb on it.
- This appliance can be used by children aged from 8 years and above and persons with reduced physical, sensory or mental capabilities or lack of experience and knowledge if they have been given supervision or instruction concerning use of the appliance in a safe way and understand the hazards involved. Children shall not play with the appliance. Cleaning and user maintenance shall not be made

SAFETY INFORMATION

by children without supervision.

- Water attracts children; always attach a spa cover after each use.

DANGER - Risk of Accidental Drowning (especially children under 5 years). Caution shall be exercised to prevent unauthorized access to the spa by children. This can be reached by adult supervisor securing the means of access or installing a safety protection device to the spa. To avoid accidents during spa use, ensure that children are kept under constant adult supervision.

WARNINGS - SAFE WATER MAINTENANCE AND CHEMICAL USE

- Never add water to chemicals. Always add chemicals to water to avoid strong fumes or violent reactions that may result in hazardous chemical spray.
- Regarding the information pertaining to cleaning, maintenance of water, and disposal of water, please see the "MAINTENANCE" section.
- Do not use spa during chemical maintenance.
- Any manual dosing of chemicals shall not be performed while bathers are present in the spa.
- Consult your local government authority for water regulations related to convenient water supply for filling the spa.

WARNINGS - SAFE SETUP AND STORAGE

• We strongly recommend not to unfolding and inflating the spa if the ambient temperature is below 15°C (59°F). We suggest inflating the spa indoors, and then continuing to setup outdoors. If the outdoor temperature is lower than 6°C (42.8°F), the spa heater must always be on. In this mode, the Freeze Shield® system can keep the internal temperature between 6°C (42.8°F) and 10°C (50°F) to prevent damage, such as water freezing in the pipes or the circulation system.

CAUTION: If alarms pop up on the spa, the Freeze Shield® system will stop working. Be sure to check the status of your spa if the outdoor temperature is below 6°C (42.8°F). In case of a long-term absence from home when there is a risk of temperatures falling below 6°C (42.8°F), we strongly suggest disassembling the spa and storing it following the storage procedure.

- When the appliance will be not used for a long time, such as in the winter, the spa or pool set should be disassembled and stored indoors.
- Do not to place the spa on a slippery surface and make sure the surface is free of sharp objects before installation.
- To avoid damage to the pump, the spa must never be operated unless the spa is filled with water.
- For safety reasons, only use the accessories provided or approved by the spa manufacturer.
- Regarding the information pertaining to the installation, refer to the following paragraph of the manual.
- Whenever the spa is emptied, the filter should be cleaned (and drained/dried, where applicable).
- Please examine equipment before use. Notify Bestway at the customer service address listed on this manual for any damaged or missing parts at the time of purchase. Verify that the equipment components represent the models that you had intended to purchase.
- This product is not intended for commercial use.
- Always keep the spa cover on to minimize heat loss during heating of the spa between uses (but not while it is being used). Ensure the cover is fitted tightly, as per instructions to maximize insulation. It shall be recommended that the cover, when not in use, should be kept off the ground to retain its cleanliness (particularly the surface in close proximity to the water spa water surface). The cover should be stored in an appropriate location, where it cannot be damaged, or cause damage.
- Check the set water temperature and consider lowering it for the times when the spa will typically not be in use.
- Depending on external conditions, consider turning off the heater entirely if not using the spa for an extended period of time (where the spa provides this option, but still maintains residual disinfection/pH-values).
- It is recommended to use an insulating ground cloth underneath the spa to minimize heat loss through the bottom of the spa.
- Maintain clean filters to preserve appropriate working conditions for the pump and avoid unnecessary water replacement and re-heating.

SAFETY INFORMATION

- Keep the spa away from the rest area to minimize noise disturbance.
- Do not put the cover on the ground or any other dirty surface when not in place on the spa.
- When the spa is being used, the cover should be placed in a clean, dry area, otherwise it can pick up dirt and bacteria. Covers should not be put on wooden tables or wooden decking because of the risk of bleaching the wood. A cover lifter, or similar device, is useful for ensuring that the cover does not come into contact with the ground. A cover lifter is strongly recommended for spas in rental settings.
- Recommended to ask a qualified contractor or a structural engineer to verify if the support material is strong enough to support the maximum design load of the spa, spa water and bathers. Read the filled weight information on the package.

WARNINGS – ONLY FOR SPA EQUIPPED WITH WI-FI

- Transmitter working frequency: WIFI: 2412~2472MHz; BLE: 2402~2480MHz
- Transmitter maximum output power: WIFI:19dBm; BLE:10dBm

SAVE THESE INSTRUCTIONS

DISPOSAL



Electrical products should not be disposed of with household waste. Please recycle where facilities exist. Check with your local authority or retailer for recycling advice.

TECHNICAL SAFETY INSTRUCTION

PRCD

- Before inserting plug into a power outlet, make sure the current rate of the power outlet is suitable for the pump.
- The spa is a class I electrical appliance and must be connected directly to a grounded socket. It is recommended to only use a socket which is resistant to humidity and capable of high-power loading. Regularly check the plug and socket for signs of damage before using the spa – do not use the spa if the plug or socket is damaged. If you are unsure about the quality of the electrical supply, please consult a qualified electrician before use.
- The PRCD plug must be tested before each use to avoid risk of electric shock.
- Do not use the pump if this test fails. For assistance, please visit the support section on our website, www.bestwaycorp.com.

SPA HEATER EQUIPOTENTIAL BONDING TERMINAL

- It is recommended to arrange for a qualified electrician to connect the spa pump to an equipotential bonding terminal using a minimum 2.5mm² solid copper conductor.

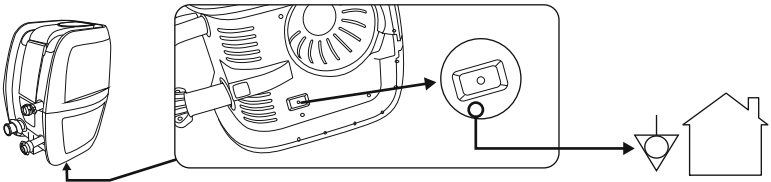

PRODUCT DESCRIPTION

HOT TUB HEATER SPECIFICATIONS:

Power Rate
220-240V AC, 50Hz, 2050W

PARTS & TOOLS NEEDED

Compare the parts in your box to the parts listed on the top of the package. Verify that the equipment components represent the model that you had intended to purchase. If any parts are damaged or missing at the time of purchase, visit our website bestwaycorp.com/support.

SETUP INSTRUCTIONS

OVERVIEW

CHOOSING THE CORRECT LOCATION:

The location chosen where the hot tub will be installed must adhere to the following conditions:

- Because of the combined weight of the water inside the hot tub and the users, the surface chosen must be capable of uniformly supporting the total weight for the entire time the hot tub is installed.
- The location selected must be no more than the length of the hot tub cord from the wall socket. The hot tub plug must be plugged directly into the wall socket.
- For both indoor and outdoor installations, adequate drainage must be present.
- The surface must be flat and smooth. If the surface is inclined or uneven, it can create an unbalanced load on the structure of the hot tub. This can damage the welding points.
- The surface must be clear of any type of object. Due to the weight of the water, any object under the hot tub could damage or perforate the bottom of the hot tub.
- The selected location must not have overhead power lines or trees. Be sure the location does not contain underground utility pipes, lines or cables of any kind.
- The selected location must be far from house entrance. Do not position any equipment or other furniture around the hot tub. The water that comes out of the hot tub during use or due to product malfunctions can damage furniture surrounding the hot tub.
- Do not assemble the hot tub on carpet or other floor materials (ex. untreated cork, timber or other porous materials) that have the potential to harbor moisture and bacteria or that could be affected by water treatment chemicals used in the hot tub.
- Consult your local government authority for installation regulations.

Suggested surfaces: grass, ground, concrete and all other surfaces that respect the above set-up conditions.

Surfaces to avoid: mud, sand, gravel, deck, balcony, driveway, platform, soft/loose soil or other surface that does not meet the above set-up conditions.

FOR WI-FI ENABLED HOT TUBS ONLY:

To choose the correct location for an app-controlled hot tub, read the hot tub Wi-Fi instruction leaflet included in the package and these instructions.

INDOOR INSTALLATION:

Be aware of these special requirements if you install the hot tub indoors.

- Humidity is a natural side effect of hot tub use that could cause damage to property without proper precaution.
- Determine the effects of moisture on exposed wood, structural materials, or surrounding objects in the proposed location.

SETUP INSTRUCTIONS

- To minimize these effects in an indoor environment, provide plenty of ventilation to the selected area. Consult an expert to confirm the installation area is properly ventilated prior to use.
- To avoid home or property damage, only install the hot tub in an area with an adequate drainage system. Water may flow out of the hot tub during filling, draining, or when in use.

OUTDOOR INSTALLATION:

Be aware of these special requirements if you install the hot tub outdoors.

- The selected surface must be clear of aggressive plants and weed species. Types of strong vegetation could grow through the liner and create water or air leakage. Grass or other vegetation that may cause odor or slime to develop must be eliminated from the chosen location.
- The selected location must not have overhead power lines or trees. Be sure the location does not contain underground utility pipes, lines or cables of any kind.
- Do not leave the hot tub's surface exposed to direct sunlight for long periods of time. We recommend protecting the hot tub from direct sunlight exposure with a cover when not in use.
- Consult a local professional installer for environmental conditions, such as ground water and risk of frost.

Follow the important requirements above to choose the correct surface and location to set up your hot tub.

NOTE: If parts become damaged because the set-up surface and location do not adhere to these instructions, it will not be considered a manufacturer defect and will void the warranty and any service claims. It is the owner's responsibility to ensure the site meets the requirements at all times.

ASSEMBLY INSTRUCTIONS

For installation instructions, scan the QR code printed on the front cover or follow the drawings printed on the top of the package. Drawings are for illustration purposes only. May not reflect actual product. Not to scale.

- Do not use an extension cord or multi-plug adapter with the hot tub heater. It is dangerous and can cause the plug to overheat, potentially damaging the equipment and surrounding items.
- Keep at least 1 m (3 ft. 3 in.) of clearance around the hot tub.
- Do not use saltwater to fill the pool. High concentrations of salt can corrode the internal metal components.
- The filtration system of the hot tub is designed to only be used with the filter cartridge. Any other component added inside the filter set can cause damage to the filtration system. This will not be covered by the warranty.

NOTE: Before assembling the hot tub, lay the liner in the sun to help soften the material and make it easier to set up.

INFLATION INFORMATION - FOR INFLATABLE HOT TUBS ONLY:

- When inflating, you will notice that air will be expelled from the area where the air hose connects to the pump. This is normal.
- Do not cover the holes on the base of the inflation hose, the inflation hose is designed to inflate the hot tub to the correct pressure. This will over-inflate the liner and damage the structure.
- Do not use an air compressor to inflate the hot tub.
- Do not drag the hot tub on rough ground as this may cause damage to the liner.
- Please inflate the hot tub when the outdoor ambient temperature is above 15°C (59°F).

FORTIFIBER™ DROP STITCH HOT TUBS ONLY:

Hand Pump Pressure Gauge

- The air pressure gauge on the hand pump only shows the air pressure when it is higher than 5 PSI, which is normal.
- When the air pressure inside the hot tub is lower than 5 PSI, the air pressure gauge will not show a value.

Air Valves



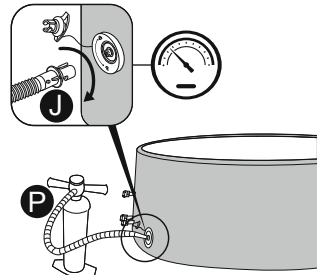

- If the air valve is loose, use the provided wrench to tighten it. With one hand, hold the backside of the air valve from the inner side of the hot tub wall and turn the wrench clockwise.
- Do not adjust the air valve connector when the hot tub is in use.

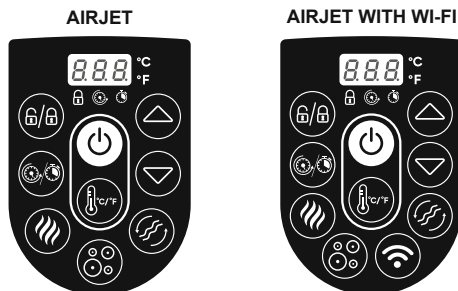

USAGE INSTRUCTIONS















CONTROL PANEL











 **ON/OFF BUTTON:** After activating the RCD/PRCD, press and hold the  button for 2 seconds. The  button will light up green and the control panel can now be used. Press and hold the  button for 2 seconds to turn off all activated functions.

 **CELSIUS/FAHRENHEIT TOGGLE:** The temperature can be displayed in either Fahrenheit or Celsius.

 **LOCK/UNLOCK BUTTON:** To lock or unlock the pump, press this button for 2 seconds. The pump also has a 5-minute auto-lock, and this light will turn on.

 **POWER-SAVING TIMER BUTTON:** Helps to avoid wasting power by setting the time and duration of the heating cycle for the hot tub. Follow these steps to activate the POWER-SAVING function:
Press the  button and the  LED starts to flash.
Press the  or  button to adjust the heating time (1-999 hours).
Press the  button again to confirm the heating time.
After setting the heating time, the  LED starts to flash.
Press the  or  button to set the timer (0-999 hours). This is the amount of time before the activation of the heating function. If the timer is set to 0 hours, the heating system will activate immediately.
Press the  button again or simply touch nothing for 10 seconds to confirm the setting. The  LED turns on, and the timer for the activation of the heating function begins. The screen flashes the current temperature and time alternately.
To modify the timer settings, press the  button and use the  or  button to adjust.
To cancel the settings, hold the  button for 2 seconds.
If the POWER-SAVING function is activated and in the waiting period, the other pump functions can still be used before the heating function is powered on.
The POWER-SAVING function is not an automatic function. After one complete cycle (timer and heating duration), this function must be set again.

 **HEAT BUTTON:** Press the  button to activate the heating system. When the light of the  button is red, the heating system is activated. When the light is green, the water has reached the set temperature.
If the heating system is activated, the filtration system will automatically start.
After turning off the heating system, the filtration system will continue to operate.



 **TEMPERATURE ADJUSTMENT BUTTONS:** Pressing the  or  buttons will activate the display, which will flash, showing the set temperature for 3 seconds. After that it will show the actual water temperature. Adjust the set temperature using the  or  button.
The default set temperature is 35°C (95°F).
Temperature adjustments range from 20°C (68°F) to 40°C (104°F).

USAGE INSTRUCTIONS



MASSAGE SYSTEM BUTTON: Press the  button to activate the massage system, which has a 30-minute auto-shutoff feature. The light of the button becomes red when activated. Do not run the massage system when the cover is attached. Air can accumulate inside the hot tub and cause irreparable damage to the cover.



WATER FILTER BUTTON: The  button turns the filter pump on and off. The  button lights up red when activated.



FOR WI-FI ENABLED HOT TUBS ONLY:

WI-FI ACTIVATION: For Wi-Fi and smartphone app operation instructions, read the hot tub Wi-Fi instruction leaflet included in the package.

THE WATER HEATER RATE MAY CHANGE IN THE CONDITIONS BELOW:

- When the outdoor temperature is below 15°C (59°F).
- If the cover is off or not in the correct position. Always keep the cover on the hot tub when it is heating up or is not in use; it minimizes heat loss while preventing dust from contaminating the water.
- The water temperature shown on the display may not be correct if the filtration system is not activated. To read the correct water temperature on the display, run the filtration system for at least a minute.
- The water temperature as tested by an external thermometer may vary from the temperature as displayed on the hot tub panel by as much as approximately 3°C (37.4°F).

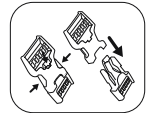

WINTER USE INSTRUCTIONS

It is important to follow these guidelines if you are setting up the hot tub during the winter. This will prevent damage to the hot tub heater and liner material, drastically extending the life of the product.



FREEZE SHIELD®

- If the outdoor temperature is below 15°C (59°F), unfold and inflate the hot tub indoors using the hot tub pump to avoid damaging the liner. This will make the hot tub liner more flexible and easier to set up.
- Continue setup outdoors by positioning the hot tub liner in the desired area, then connect the hot tub pump and fill with water. The water temperature used to fill the hot tub must be above 6°C (42.8°F), otherwise when you start the hot tub heater, the E03 alarm will appear.
- If the Freeze Shield® system isn't working, alarms will appear on the display screen. Be sure to continuously check the status of your hot tub if the outdoor temperature is below 6°C (42.8°F). If you have a long-term absence from your home when there is a risk of temperatures falling below 6°C (42.8°F), we strongly suggest disassembling the hot tub and storing it following the Disassembly and Storage Instructions.
- Any damage due to using the hot tub in these conditions is the responsibility of the customer. Do not use the hot tub when the outdoor temperature reaches -10°C (14°F); follow the Disassembly and Storage Instructions for proper procedures.

USAGE INSTRUCTIONS

HEATING TIMES

For the water to reach 40°C (104°F), the time required is based on the starting water temperature and outdoor temperature. The data below is purely for reference.

To display the current water temperature, run the filter system for at least a minute.

Outdoor Temperature	Water Temperature	Set Temperature	Heating Time
10°C (50°F)	10°C (50°F)	40°C (104°F)	16-24 hours
15°C (59°F)	15°C (59°F)	40°C (104°F)	12-20 hours
20°C (68°F)	20°C (68°F)	40°C (104°F)	10-18 hours
25°C (77°F)	25°C (77°F)	40°C (104°F)	8-12 hours
30°C (86°F)	30°C (86°F)	40°C (104°F)	5-8 hours

MAINTENANCE INSTRUCTIONS

Ensure the pump is unplugged before conducting any hot tub maintenance.

LINER

- It is normal for your hot tub liner to appear as if it is losing air due to variations in ambient temperature that may change the internal air pressure in the liner. Follow the assembly instructions and inflate to the accurate pressure, when needed.
- When detaching the pump from the liner, to avoid water from coming out of the pipes, block the pipe by screwing on the cap and installing the stoppers on the debris screens.

COVER

- The inside and outside of the cover should be cleaned periodically by using a gentle detergent for the PVC material.

FILTER CARTRIDGE

- To optimize the performance of the filtration system, check and clean your filter cartridge every day.
- We recommend changing your filter cartridge every week or replacing it if after washing, the filter cartridge remains soiled and discolored.

WATER

Many pollutants settle below the water line. These pollutants can cause bacterial, algal or fungal growth. After a while, tenacious stains or biofilms may develop on the accessible surfaces below the water line. It is recommended to clean your hot tub as regularly as needed.

- To keep your water clean, run the filtration system and perform chemical maintenance every day. The filtration system eliminates the debris in the water and the chemical maintenance sanitizes the water.
NOTE: When performing the chemical maintenance, use the chemical dispenser with tablets only (do not use granules). Don't throw chemical products (tablets, granules or liquid) directly in the water; the chemicals will settle on the bottom of the hot tub, damage the material and discolor the PVC.
- Water quality will be directly related to frequency of use, number of users and overall maintenance of the hot tub. The water should be changed every 3 days if there is no chemical treatment being performed. It is highly recommended to use tap water to fill the hot tub to minimize the influence of unwanted pollutants, such as minerals.
- We recommend taking a shower before using your hot tub, as cosmetic products, lotions and other residues on the skin can quickly degrade water quality.

MAINTENANCE INSTRUCTIONS

Chemical Tablets (Not Included):

- Remove the chemical dispenser from the hot tub when the hot tub is in use.
- After performing chemical maintenance and before using the hot tub, use a test kit (not included) to test the water chemistry. We recommend maintaining your water chemical balance as follows:

Total Alkalinity	pH	Calcium Hardness	Cyanuric Acid	Free Available Chlorine
80-120 ppm	7.4-7.6	200-400 ppm	30-50 ppm	2.0-4.0 ppm

- Hot tub damage resulting from misuse of chemicals and mismanagement of water is not covered by the warranty.
- Pool chemicals are potentially toxic and should be handled with care. There are serious health risks from chemical vapors and the incorrect labeling and storage of chemical containers.
- Please consult your local pool or chemical supply retailer for more information about chemical maintenance. Pay close attention to the chemical manufacturer's instructions.
- Over-usage of chemicals will damage the hot tub, including but not limited to discoloration of the printing, damaged welding points in the material and liner deterioration.

DISASSEMBLY & STORAGE INSTRUCTIONS



DRAINING

To drain the hot tub, follow the drawings. Drawings are for illustration purposes only. May not reflect actual product. Not to scale.



DRYING

- To dry the different parts of the hot tub, follow the drawings. Drawings are for illustration purposes only. May not reflect actual product. Not to scale.
- After draining the hot tub, some water may remain in the pump, liner chamber, massage chain and inflatable cover. Make sure that all of these parts of the hot tub are completely dry. This is essential to extend the life of the hot tub and to avoid mildew.
- The water inside the liner chamber and the inflatable cover is from the humidity in the air used to inflate them. The amount of water will vary depending on the amount of humidity in your area.



CLEANING

Detergent residue and dissolved solids from bathing suits and chemicals may build up on the hot tub walls. Use soap and water to clean the walls and rinse thoroughly. Do not use hard brushes or abrasive cleaners.

DISASSEMBLY & STORAGE INSTRUCTIONS



DEFLATING

The following is NOT applicable to ThermaCore™ Foam Hot Tubs.

2a for inflatable hot tubs only.

2b for FortiFiber™ Drop Stitch hot tubs only.

- To deflate the hot tub, follow the drawings. Drawings are for illustration purposes only. May not reflect actual product. Not to scale.
- The hot tub is equipped with a deflation function to remove all the air from inside the chamber to make it easier to pack and store.

REPAIRING

When repairing the cover or interior floor:

Use the provided repair patch to repair tears or punctures.

- Clean the area, and carefully peel the patch.
- Stick the patch over the damaged area.
- Wait 30 seconds before re-inflation.

When repairing the walls or exterior floor:



Use the provided repair patch and glue (not included) to repair tears or punctures.

- Clean and dry the area to be repaired.
- Cut the provided patch to the appropriate size. DO NOT peel the patch.
- Use glue (not included) to coat one side of the newly cut patch. Make sure the glue is evenly distributed. Wait for 30 seconds and then place the patch with glue over the damaged area.
- Smooth out any trapped air bubbles and press down firmly for two minutes.
- Wait 30 minutes before re-inflation.

STORAGE

- Remove all accessories and make sure the hot tub liner, inflatable cover, pump and accessories are completely clean and dry before storing. If the hot tub is not completely dry, mold may form and damage the hot tub liner during the storage period.
- Fold the hot tub liner only if the ambient temperature is above 15°C (59°F) to ensure pliability.
- Store the hot tub in a dry place with a moderate temperature between 15°C (59°F) and 38°C (100°F).
- We strongly recommend positioning the hot tub liner and inflatable cover inside a carton box to better protect the material during the winter months.

TROUBLESHOOTING

Problems	Probable Causes	Solutions
Pump stopped working	Power failure.	Check power source.
	Power circuit is broken.	For assistance, please visit the support section on our website, www.bestwaycorp.com .
Pump is not heating properly with lid	Temperature set too low.	Set the hot tub to a higher temperature; refer to pump operation section.
	Dirty filter cartridge.	Clean/replace the filter cartridge (refer to Filter Cartridge Cleaning and Replacement section).
	Hot tub is not covered properly with lid.	Properly attach the cover.
	Heating element failure.	For assistance, please visit the support section on our website, www.bestwaycorp.com .
Massage system is not working	Air pump is overheating.	Unplug the pump, wait two hours until the pump is cool, insert the plug and press the Massage System Button.
	Massage stops automatically after 30 minutes.	Press the Massage System Button to reactivate.
	Air pump is broken.	For assistance, please visit the support section on our website, www.bestwaycorp.com .
Pump adapters are not level with the hot tub adapters	The material will change shape; this is normal.	Elevate the pump with wood or another type of insulated material to bring the pump's adapters to the same level as the hot tub's adapters.
Hot tub air is leaking	Hot tub is torn or punctured.	Use provided repair patch
	Air valve is loose.	Using soapy water, cover the air valve to check if air is leaking – the soap will bubble where there is a leak. If so: <ul style="list-style-type: none"> • Fasten the air valve by turning it clockwise. • FortiFiber™ Drop Stitch Hot Tubs: Deflate the hot tub, and with one hand, hold the backside of the air valve from the inner side of the hot tub wall and turn the wrench clockwise.
Water is not clean	Insufficient filtering time.	Increase filtration time.
	Dirty filter cartridge.	Clean/replace the filter cartridge (refer to Filter Cartridge Cleaning and Replacement section).
	Improper water maintenance.	Refer to the chemical manufacturer's instructions.
RCD/PRCD test failed	Hot tub or RCD/PRCD is defective.	For assistance, please visit the support section on our website, www.bestwaycorp.com .
The RCD/PRCD light indicator is solidly yellow	The RCD/PRCD detects a high temperature.	<ul style="list-style-type: none"> • Check if there are any abnormalities or signs of overheating on the body and plug area of the RCD/PRCD or on the external surface of the wall socket, where the RCD/PRCD is connected. If there are no abnormalities or signs of overheating, unplug it and wait one hour, then plug it into the wall socket. <ul style="list-style-type: none"> - If the yellow light disappears, continue to use the product. - If the yellow light stays on, stop using the product, call an electrician to inspect the wall socket. • For assistance, please visit the support section on our website, www.bestwaycorp.com.
Control panel is not working	The control panel has an auto-lock, which is activated after 5 minutes of inactivity; if the lock icon  is highlighted, the control panel is locked.	<ol style="list-style-type: none"> 1. To unlock the control panel, press the  button for 3 seconds. If the control panel will not unlock, restart the pump – unplug and plug it back in. 2. Press the  button for 2 seconds if the problem persists.
	Control panel is not activated.	For assistance, please visit the support section on our website, www.bestwaycorp.com .

TROUBLESHOOTING

Problems	Probable Causes	Solutions
Water leaks from the adapters between the pump and hot tub	Seals are missing inside the pump adapters.	Insert the stopper caps on the hot tub ports to prevent the water from escaping and disconnect the pump. Check if the seals are in place.
	Seals are not in the correct position.	If the seals are not in the correct position, open the gears and place the seals in the correct position.
	Seals are damaged.	If the seals are damaged, they must be replaced. For assistance, please visit the support section on our website, www.bestwaycorp.com .
	Adapters are not tightened correctly.	If the seals are in the correct position, then the adapters are not tightened correctly. Connect the pump to the hot tub, hand-tighten the adapters and remove the stopper caps from the hot tub ports. If it is still leaking, tighten the adapter until it isn't.

FOR WI-FI ENABLED HOT TUBS ONLY



Problems	Probable Causes	Solutions
The Wi-Fi setup is not successful	The pump has been connected to the wrong band.	If the router your pump is connected to is dual-band and currently not connecting to a 2.4GHz network, please switch to another band of the same router (2.4GHz) and try to pair pump heater again. 5GHz networks are not supported.
	The hot tub pump location is too far from the router.	Check with your cell phone to see if there is full Wi-Fi signal. If the strength of the signal on your phone is too low, check where the strength of the Wi-Fi signal is full and place the hot tub in that position.
	The pump was connected to the wrong Wi-Fi name.	Start the connection procedures again and be sure that the network name is typed correctly.
	The Wi-Fi password used during the connection is wrong.	Start the connection procedures again and be sure that the password is correct.
	The strength of the Wi-Fi signal is not stable.	1. Check that the router works correctly. 2. Go near the hot tub and check the signal on your phone. If the signal strength is not stable, check the condition of your router. If the signal strength is full, repeat the procedures to connect the hot tub to the network.
	There is an appliance near the hot tub pump or the router that creates signal interference.	The Wi-Fi connectivity can be interrupted by electromagnetic or other interferences. Keep the appliance away from other electronic devices that may cause interference.
	Your phone will not connect to the Wi-Fi network during the registration.	Check if the mobile device is in airplane mode. Make sure to have the airplane mode deactivated when connecting to the Wi-Fi network.
	There is an issue with the app.	Consult the Help section in the app for extensive and up-to-date troubleshooting tips. For assistance, please visit the support section on our website, www.bestwaycorp.com .

TROUBLESHOOTING





WI-FI LED LIGHT STATUS

Light Status	Meaning	Solutions
Light flashes slowly	Ready to connect to the router.	Connect to the Wi-Fi using your phone.
Light is on	Connected to the router.	N/A - already connected to the Wi-Fi.
Light flashes quickly	Lost Wi-Fi signal.	Check the status of your router and repeat the procedures to connect the hot tub to the network.
Light is off	Light is damaged / Problem with Wi-Fi module.	For assistance, please visit the support section on our website, www.bestwaycorp.com .





ERROR CODES

Error Code	Probable Causes	Solutions
<p>The water flow sensors work without pressing the filter or heat button.</p> 	The water flow sensor flags didn't fall back into the correct position.	Unplug the plug gently, strike the side of the pump but not violently, and plug it back in.
	The water flow sensors are broken.	For assistance, please visit the support section on our website, www.bestwaycorp.com .
<p>The water flow sensors do not detect enough water during the filtering and/or heating functions.</p> 	The 2 stopper caps are still inside the pool.	Remove the 2 stopper caps before heating. Refer to the Assembly section for more information.
	The filter cartridge is dirty.	Remove the filter set from inside the hot tub and push the filter or heat button. If no alarm appears, clean or change the filter cartridge in the pump.
	<p>Activate the filter or heat system and put your hand in front of the outlet pipe inside the pool to check if you can feel water flowing out.</p> <ul style="list-style-type: none"> If no water flows out, the water pump is broken. If water flows out but the alarm still appears, the water flow sensors are broken. 	For assistance, please visit the support section on our website, www.bestwaycorp.com .
	The filter is blocked.	<ol style="list-style-type: none"> Clean the filter and check for damage. Replace or re-install as necessary. For assistance, please visit the support section on our website, www.bestwaycorp.com.
	The pipes in the liner are bent or have poor water flow.	Check the hot tub connection to see if the pipes are bending. For assistance, please visit the support section on our website, www.bestwaycorp.com .
	The debris screens are blocked by hard water due to calcium build-up.	<ol style="list-style-type: none"> Empty the hot tub and place a garden hose inside the pipes to wash away the debris. To be sure all the debris is removed, do this from the outside and inside of the hot tub. Use a toothbrush to remove any stubborn debris. For assistance, please visit the support section on our website, www.bestwaycorp.com.

ERROR CODES

Error Code	Probable Causes	Solutions
<p>The water flow sensors do not detect enough water during the filtering and/or heating functions.</p> 	The washers are worn or damaged.	<ol style="list-style-type: none"> 1. Check the washers inside the coupling for damage. Unscrew the couplings and remove the washer for further inspection. 2. For assistance, please visit the support section on our website, www.bestwaycorp.com.
<p>The pump's thermometer reads the water temperature below 4°C (39°F).</p> 	The water temperature is lower than 4°C (39°F).	The hot tub is not designed to operate with water temperatures lower than 4°C (39°F). Unplug the pump and only re-start the pump when the water temperature reaches 10°C (50°F).
	If the water temperature is higher than 4°C (39°F), the pump's thermometer is broken.	For assistance, please visit the support section on our website, www.bestwaycorp.com .
<p>The pump's thermometer reads the water temperature as over 50°C (122°F).</p> 	The water temperature is over 50°C (122°F).	The hot tub is not designed to operate with water temperatures greater than 40°C (104°F). Unplug the pump and restart it when the water temperature reaches 38°C (100°F) or lower.
	The ambient temperature is higher than 40°C (104°F) or the hot tub has been exposed to direct sunlight for an extended period.	Unplug and detach the pump and drain the hot tub. After 15 minutes, reattach the pump, plug it back in and restart the heating function. If the alarm appears again, consider moving the hot tub to another location without direct sunlight.
	If the water temperature is lower than 40°C (104°F), the pump's thermometer is broken.	For assistance, please visit the support section on our website, www.bestwaycorp.com .
<p>The pump's thermometer connection has issues.</p> 	The connection between the temperature sensor and the PCB may have an issue.	Unplug the hot tub, wait 5 minutes, and then plug it back in while switching the pump on. If the alarm appears again, please visit the support section on our website, www.bestwaycorp.com .
<p>The pump's thermometer reads the water temperature as over 52°C (125.6°F).</p> 	The water temperature is over 52°C (125.6°F).	The hot tub is not designed to operate with water temperatures greater than 40°C (104°F). Unplug the pump and restart it when the water temperature reaches 38°C (100°F) or lower.
	The ambient temperature is higher than 40°C (104°F) or the hot tub has been exposed to direct sunlight for an extended period.	Unplug and detach the pump and drain the hot tub. After 15 minutes, reattach the pump, plug it back in and restart the heating function. If the alarm appears again, consider moving the hot tub to another location without direct sunlight.
	If the water temperature is lower than 40°C (104°F), the pump's thermometer is broken.	For assistance, please visit the support section on our website, www.bestwaycorp.com .

ERROR CODES

Error Code	Probable Causes	Solutions
<p>Wi-Fi module connection failed.</p> 	The Wi-Fi module is damaged.	For assistance, please visit the support section on our website, www.bestwaycorp.com . NOTE: Press any button to remove the alarm and continue to use the hot tub without the Wi-Fi connection.
<p>Electricity is detected from the ground wire.</p> 	An appliance in your home may have an electric leak.	Call an electrician immediately to understand if power is flowing inside the grounding connection. If the problem continues, to use your hot tub safely, we strongly recommend connecting the hot tub plug to a socket with independent grounding.
	The pump has a problem.	For assistance, please visit the support section on our website, www.bestwaycorp.com .
<p>The power board temperature is too high.</p> 	The power board has a problem.	For assistance, please visit the support section on our website, www.bestwaycorp.com .
<p>Ground connection failed.</p> 	The ground system of the wall socket where the hot tub is connected has a problem.	Connect the hot tub pump to a new socket or call an electrician to check the wall socket. If the problem continues, we suggest creating an independent grounding connection to the wall socket.
	The pump has a problem.	For assistance, please visit the support section on our website, www.bestwaycorp.com .

WARRANTY TERMS

- Bestway Manufacturer Warranty does not cover products that have been opened and/or tampered with, without Bestway's consent (for example but not limited to, opening a pump).
- For support and product registration, please visit bestwaycorp.com/support.

The Product Security and Telecommunications Infrastructure (Security Requirements for Relevant Connectable Products) Regulations 2023 Statements of Compliance

Manufacturer Name: Bestway Inflatables & Material Corp.

Address: No. 208 Jin Yuan Wu Road, Shanghai, 201812, China

Product Name: SPA

Brand name: Bestway

Model: S100202; S200202; S300202; S400202

Batch: The batch number can be found on the spa pump.

Base on 2023 No. Consumer protection for security and telecommunication infrastructure(PSTI) regulations 2023 , We, Bestway Inflatables & Material Corp., hereby declare that the device referenced above complies with the following requirements given in the ETSI EN 303 645 V2.1.1 (2020-06) for Provision 5.1-1, 5.1-2, 5.2-1, 5.3-13 (test case as below) and We have complied with the deemed compliance conditions in Schedule 2 of 2023 No.CONSUMER PROTECTION The Product Security and Telecommunications Infrastructure (Security Requirements for Relevant Connectable Products) Regulations 2023. Moreover, The defined support period for the product that was correct when the manufacturer first supplied the product. It is available on [<https://www.bestwaycorp.co.uk/Policy/ProductSecurityPolicy>]

The Product Security and Telecommunications Infrastructure (Security Requirements for Relevant Connectable Products) Regulations 2023	ETSI EN 303645
Password	provision 5.1-1 provision 5.1-2
Information on how to report security issues	provision 5.2-1
Information on minimum security update periods	provision 5.3-13

Name and Function: Mi Huang, Compliance Manager

Signature: 

Tel: 86 21 69133312 E-Mail: mi.huang@bestwaycorp.com

Date: 2025/5/26 Place: Shanghai, China



For support please visit us at:
bestwaycorp.com/support



©2025 Bestway Inflatables & Material Corp.

All rights reserved / Tous droits réservés / Todos los derechos reservados / Alle Rechte vorbehalten / Tutti i diritti riservati
Trademarks used in some countries under license from / Marques déposées utilisées dans certains pays sous licence de / Marcas comerciales utilizadas en algunos países bajo licencia de / Marken, abweichend in bestimmten Ländern unter Lizenz von / I marchi commerciali sono utilizzati in alcuni paesi su licenza **Bestway Inflatables & Material Corp.**

Manufactured by / Fabriqué par / Fabricado por / Produziert von / Prodotto da **Bestway Inflatables & Material Corp., No. 208 Jin Yuan Wu Road, Shanghai, 201812, China.**

Exported by / Exporté par / Exportado por / Exportiert von / Esportato da **Bestway (Hong Kong) International Ltd./Bestway Enterprise Company Limited, Suite 713, 7/Floor, East Wing, Tsim Sha Tsui Centre, 66 Mody Road, Kowloon, Hong Kong.**

Manufactured for, distributed and represented in the European Union by / Fabriqué pour, distribué et représenté dans l'Union européenne par / Fabricado, distribuido y representado en la Unión Europea por / Hergestellt für Vertrieb sowie Vertretung innerhalb der Europäischen Union durch / Fabricato per conto di, distribuito e rappresentato nell'Unione Europea da **Bestway Europe S.p.a., Via Resistenza, 5, 20098 San Giuliano Milanese (Milano), Italy.**

Represented in United Kingdom by **Bestway Corp UK Ltd, 8 Wentworth Road, Heathfield Industrial Estate, Newton Abbot, Devon, TQ12 6TL.**

Represented in Latin America by / Représenté en Amérique latine par / Representado en Latinoamérica por / Representado na América Latina por **Bestway Central & South America Ltda, Salar Ascotan 1282, Parque Enea, Pudahuel, Santiago, Chile.**

Represented in Australia & New Zealand by **Bestway Australia Pty Ltd, Unit 2/98-104 Carnarvon St Silverwater, NSW 2128, Australia.**

(Tel: Australia: (+61) 2 9037 1388; New Zealand: 6498 877 182).

Represented in North America by / Représenté en Amérique du Nord par / Representado en Norteamérica por **Bestway (USA) Inc., 3435 S.**

McQueen Road, Chandler, AZ 85286, United States of America.

www.bestwaycorp.com