

biard

BLBATH52

BLBATH53

BLBATH54

Installation Guide

Contents

Safety Information **Page - 2**

Installation **Page - 3**

Warranty Information **Page - 5**

Recycling & Disposal **Page - 5**

Safety Information

Please read carefully...

- ✓ Switch off the power while installing
- ✗ Do not use this product with a dimmer switch
- ✓ We recommend installation is performed by a qualified electrician
- ✓ Avoid looking directly into the light when switched on.
- ✗ Do not modify this product, this will invalidate your warranty
- ✗ Read all the instructions in the manual before beginning installation if in doubt use a qualified electrician.
- ✓ IP44 - For indoor use only.
- ✓ Inspect the product for damage before installation.

Other Information

RISK OF FIRE

Clearance required from Floor- Min 5 feet
Clearance from any flammable material - Minimum 6 inches

Parts required-

Product.:BLBATH52
Product.:BLBATH53

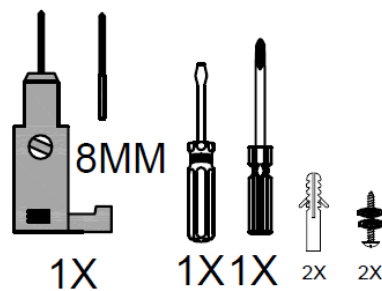

Product.:BLBATH54

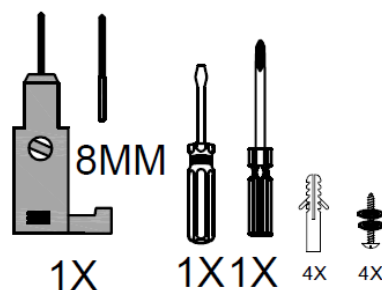

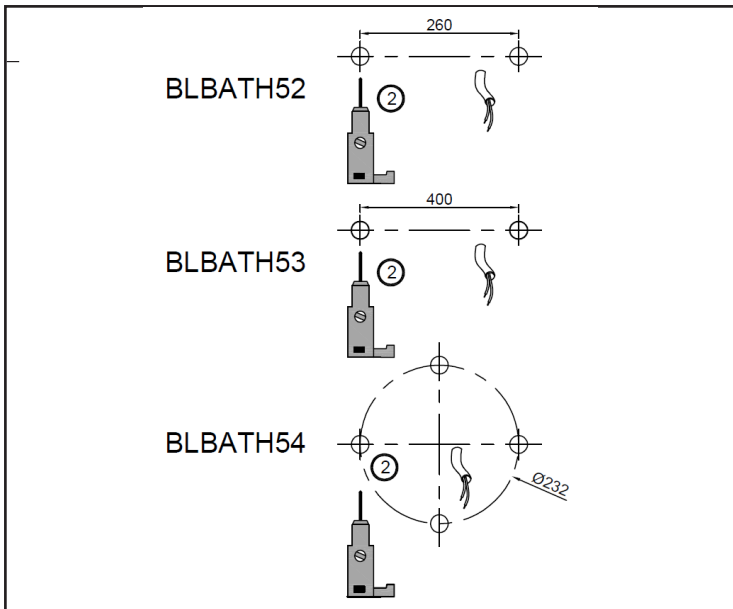

Mark out the drill centers and drill the fixing holes into the ceiling.

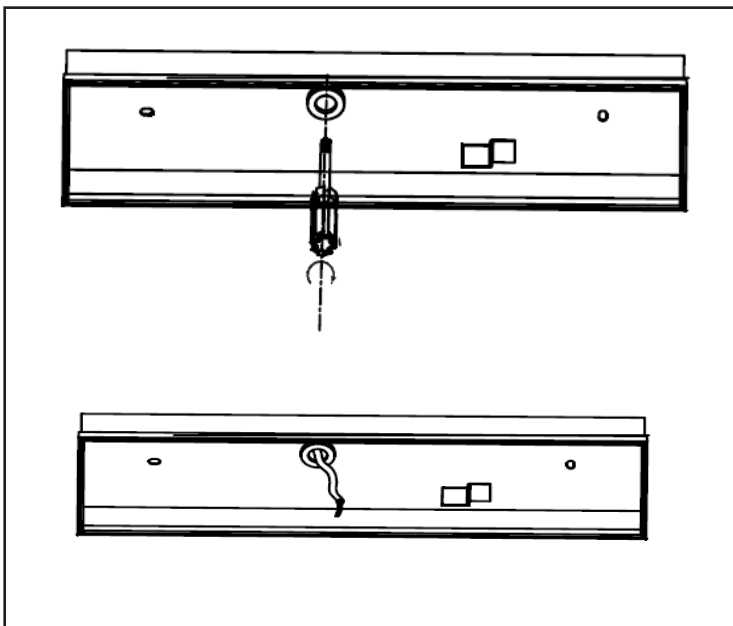

use a screwdriver to puncture a hole in the ceiling-mounting box, then feed through the power cable.

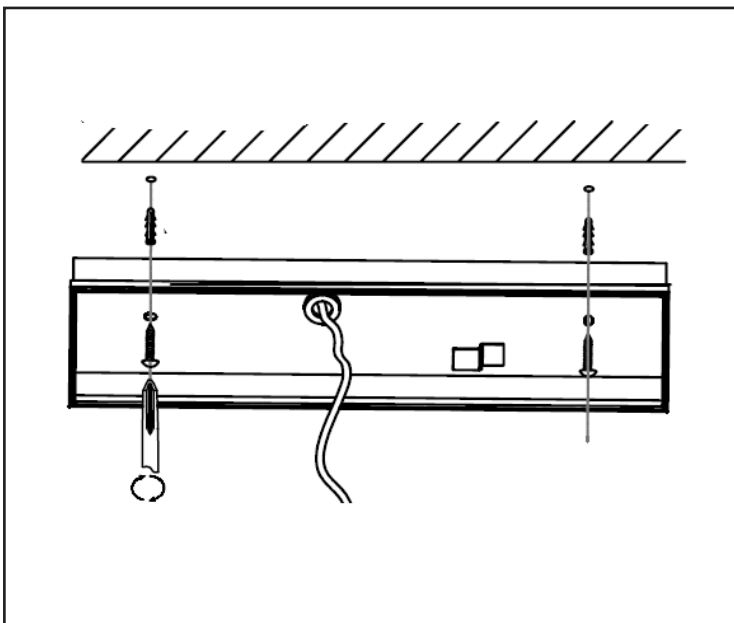

Mount the ceiling box using the provided fixings.

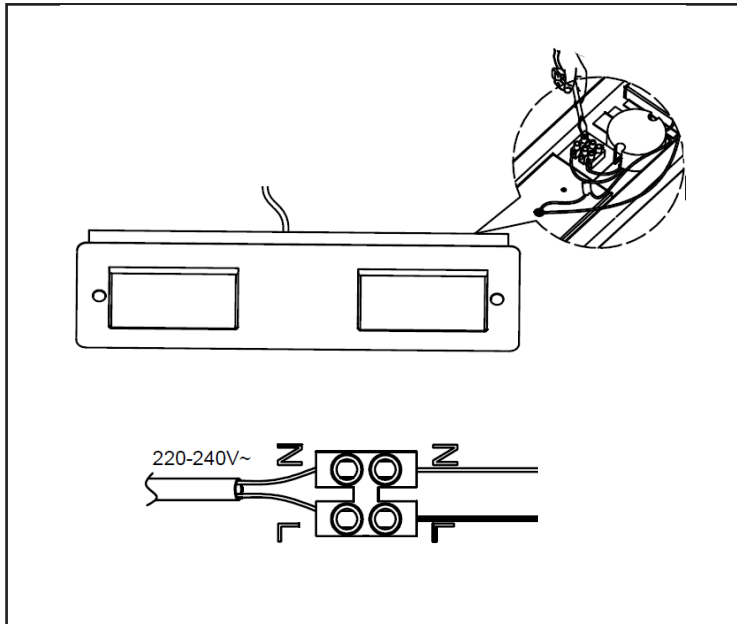

Connect the power cable to the wiring block as shown.

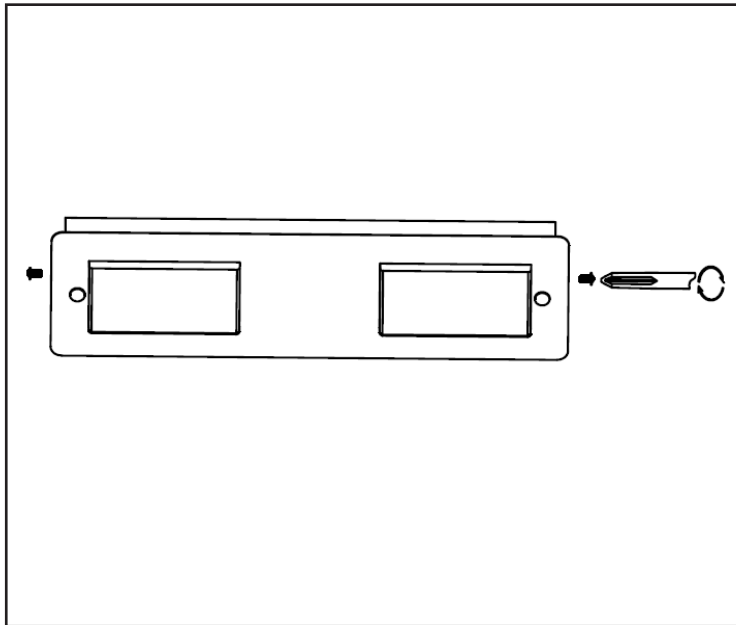

Offer the LED fitting up to the ceiling plate and fix in place with the provided screws.

The Power can now be turned on.

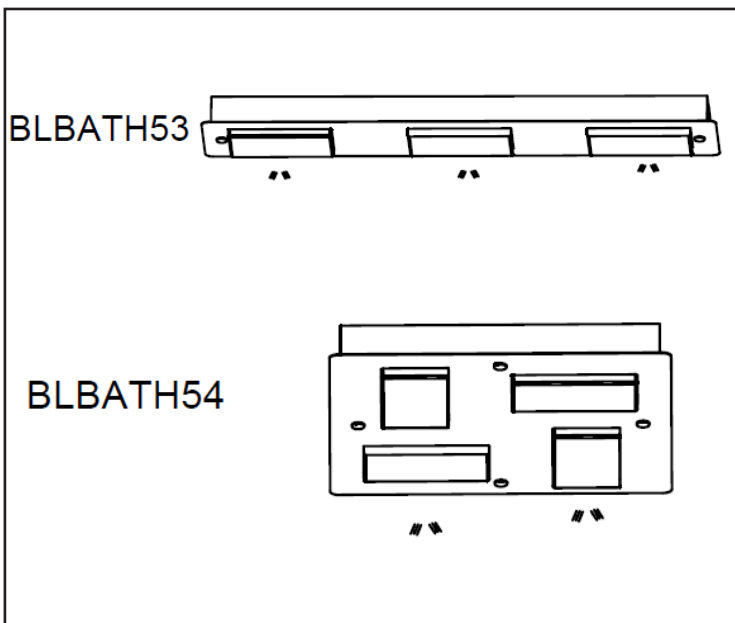

The BLBATH53 has two fixing screws to attach to the ceiling plate, the BLBATH54 has four.

Warranty Information

- *This product is covered by a 5 year limited warranty for any manufacturing faults.*
- *The warranty starts from the date of purchase.*
- *Labour costs for installation of the Product are not covered under this warranty.*
- *The warranty is only valid when products are properly installed and operated as specified in this manual and the data sheets.*
- *All warranty queries should be through the stockist that the product was purchased through.*

Recycling & Disposal

The Waste Electrical and Electronic Equipment Directive (WEEE Directive) is the **European Community directive** 2012/19/EU on **Waste Electrical and Electronic Equipment (WEEE)** which, together with the **RoHS Directive** 2002/95/EC, became European Law in February 2003

The **WEEE** directive aims to reduce the amount of electrical equipment being produced and to encourage everyone to reuse, recycle and recover it.

In support of these guidelines and for environmental safety, do not dispose of any electrical equipment including those marked with the below symbols

When replacing old electrical devices with new ones the retailer is legally obligated to take back your old items for disposal free of charge. You can also recycle your old electrical devices free of charge at your local recycling centre. Please contact your local council for more information.

